

pressure



JOFRA™ IPI Series

Industrial Pressure Indicator

NOTICE
Now with new upgraded
system B pump and
Ex certification

Pressure indicator offering user-friendly features and reliable performance

Pressure range

IPI030C	Vacuum to 30 psi / 2 bar
IPI100C	Vacuum to 100 psi / 7 bar
IPI300C	Vacuum to 300 psi / 21 bar
IPI500C	Vacuum to 500 psi / 35 bar
IPI015G	0 to 15 psi / 1 bar
IPI01KG	0 to 1,000 psi / 70 bar
IPI02KG	0 to 2,000 psi / 140 bar
IPI03KG	0 to 3,000 psi / 200 bar
IPI05KG	0 to 5,000 psi / 350 bar
IPI10KG	0 to 10,000 psi / 700 bar

High accuracy

±0.05% of F.S. for positive pressure
Vacuum ranges to 500 psi (35 bar)

Ideal for on-site use

Available as indicators, in complete test systems, or use with M&G diaphragm seals in your process application

High flexibility

Easily disassemble the test system and use the indicator for other tasks

True field indicator

Lightweight and portable with full temperature-compensation, long battery life and large display for easy visibility

Record min and max readings

Capture the min and max pressure readings for safety valve applications

Ex Certification

Certified by CSA as conforming to relevant Canadian and USA standards

Complete marine program

Part of a complete program of marine approved temperature, pressure and signal calibrators; including temperature sensors

See more at www.jofra.com

ISO 9001 Manufacturer

The IPI is available as an indicator or in one of 6 test ready systems that are complete and equipped to meet your pressure measuring or testing needs. You can use the IPI in applications from safety valve checks to system pressure verification.



PRODUCT DESCRIPTION

JOFRA IPI indicators are the latest addition to our pressure instrument offering. These handy instruments bring together the ease of an analog gauge with the accuracy and easy-to-read display of a digital calibrator.

This series is designed to meet your pressure measurement applications and make the tasks easier. The IPI offers 18 different pressure units, long battery life, high accuracy, and even serial communications. The accuracy of the IPI rivals that of a pressure calibrator and is temperature compensated for shop or in process applications. This versatile unit is available as a stand alone indicator, in a complete test system, and can be attached to M&G diaphragm seals for true in process applications.

You can perform a calibration locally without returning the IPI unit to the manufacturer. All you need is an accurate pressure reference. If you do require factory calibration, the pump and indicator are independent and only the indicator needs to be returned.

With the IPI, you get a versatile and easy-to-use pressure indicator with a fast and straightforward setup, intuitive functions, and application flexibility.

AMETEK®
CALIBRATION INSTRUMENTS

JOFRA IPI INDICATOR

The IPI digital pressure indicator takes the concept of an analog test gauge, and brings it to a new level. The IPI combines the accuracy of digital technology with the simplicity of an analog gauge, and achieves performance, ease-of-use, and a feature set unmatched in the pressure measurement world. Setup of the IPI is fast and straightforward, through a menu-driven display, with minimal text, and intuitive functions, that is simple enough to allow the indicator to be used anywhere in the world, without the need for multilingual displays. And the availability of optional sanitary seals that meet 3A standards per specification 37-01 allow the IPI to be used in virtually any application.

Protective boot

Standard configuration IPI units and those supplied with systems are delivered with a protective boot. Units with back mounting and the 24 VDC power supply are not delivered with the protective boot due to design limitations.



ON / OFF

Auto shut-off to extend battery life (user programmable).

MAX / MIN

A MIN/MAX function reads the maximum and minimum pressure that have been automatically stored. Monitor a safety valve or look for pressure spikes in the process.

ZERO

Keep the high accuracy: ZERO the instrument before every test.



Clear dual line display

The 5 digit backlit display provides an easy-to-read indication, even from a distance. Large digits display the pressure and icons show engineering units, low battery indication and battery life indication. This pressure is also shown as a percentage of range on a 20 segment bar graph. You can also read temperature and actual battery voltage on the display through the use of CONFIG key.

ENTER

Save selections and turn the backlight on and off.

Pressure connections

1/4" NPT male lower connection is standard. A 1/4" BSP male adapter is included. A 1/4" NPT male back connection is optional.

Serial interface

Serial communications port is accessible through the back of the case. Use this for calibration and to access data.

External power input option

A 24 VDC power supply connection may be ordered as an option. Terminals are accessible from the back of the case.

CONFIG

This is the key to access all user-settable functions. The CONFIG key is used in conjunction with the ▼ and ▲ functions on the ZERO and MAX/MIN keys to select and change different functions.

You can set one of 18 engineering units, change the auto-shutoff function setting, display the actual battery voltage, display the actual temperature (in °C or °F), turn the dampening on or off, change the sample rate, and set the Tare value.

OPERATIONAL SPECIFICATIONS

Pressure range

psi..... vacuum to 30, 100, 300, 500
 bar vacuum to 2, 7, 21, 35
 psi..... 0 to 15, 1,000, 2,000, 3,000, 5,000, 10,000
 bar 0 to 1, 70, 140, 200, 350, 700

Engineering units

User defined One user-definable unit
 User selectable 18 units
 (psi, inH₂O@4°C, inH₂O@20°C, inH₂O@60°F, inHg@0°C, ftH₂O@4°C,
 ftH₂O@20°C, ftH₂O@60°F, bar, mbar, kPa, kg/cm², cmH₂O@4°C,
 cmH₂O@20°C, mH₂O@4°C, mH₂O@20°C, mmHg@0°C, Torr)

Pressure accuracy

Pressure ±0.05% F.S.
 Full temperature compensation 0 to 50°C / 32 to 122°F
 Vacuum (30, 100, 300, 500 psi indicator) ±0.25% F.S.
 Vacuum (2, 7, 21, 35 bar indicator) ±0.25% F.S.

Including non-linearity, hysteresis, repeatability, and temperature effect.

F.S. (full scale) = maximum gauge pressure in psi

Serial communication interface

Connector Stereo jack
 Serial 0-3 VDC, 9600 baud, 8 data, no parity, 1 stop
 Protocol ASCII command language

Media compatibility

Liquids and gasses compatible with 316 stainless steel.

Environmental

Storage temperature -20 to 70°C / -4 to 158°F
 Operating temperature -10 to 55°C / -14 to 131°F

Pressure connection

All ranges 1/4" NPT male
 Adapters to 1/4" BSP male are included as standard

Pressure overload

Overload ranges 15 to 500 psi / 1 to 35 bar 3X range
 Overload ranges 1,000 to 5,000 psi / 70 to 350 bar .. 2X range
 Overload range 10,000 psi / 700 bar 1.5X range
 Overload alarm OL on display
 Overload alarm range 1.2X range

Display

Display Backlight, blue
 Display resolution 5 digit floating decimal
 Bar graph 20 segment, 0 to 100%
 Display indicators Engineering units icon
 Low battery indication icon
 Battery life indication utilizing bar graph
 Display update twice per second

Power supply

Battery (3) AA Alkaline
 Battery life 1500 operational hours without backlight
 Battery life 2000 operational hours without backlight
 at low sampling rate
 Battery life 150 operational hours with backlight
 Low battery indicator at 3 VDC
 Optional input port 24 VDC connection connection ^{1) 2) 3)}

- 1) Units delivered with 24 VDC power supply connection are not supplied with batteries
- 2) Batteries should not be installed when using 24 VDC power supply as damage to the IPI may occur
- 3) Units with 24 VDC power supply connection cannot be ordered with the protective boot option

Instrument dimensions

Indicator L x W x H 4.9 x 4.4 x 1.5 in / 125 x 111 x 38 mm
 Indicator weight (including battery) 1.6 lb / 0.7 kg
 Input port 1/4" NPT Male lower connection
 Optional input port 1/4" NPT Male back connection ¹⁾

- 3) Units with back connection cannot be ordered with the protective boot option

Shipping dimensions

Indicator L x W x H 9.8 x 6.3 x 3.9 in / 250 x 160 x 100 mm
 Indicator weight 1.8 lb / 0.8 kg

Instrument case

Rating NEMA 4/IP65 ¹⁾

- 1) Does not apply if the serial connection is in use or if the external 24 VDC power option is used.

Approvals

CE Conformity EN61326: 1998
 DNV Marine Approval, Certificate no.: A-9557
 Ex certification by CSA (USA) Class 1, Div. 2, Groups A-D

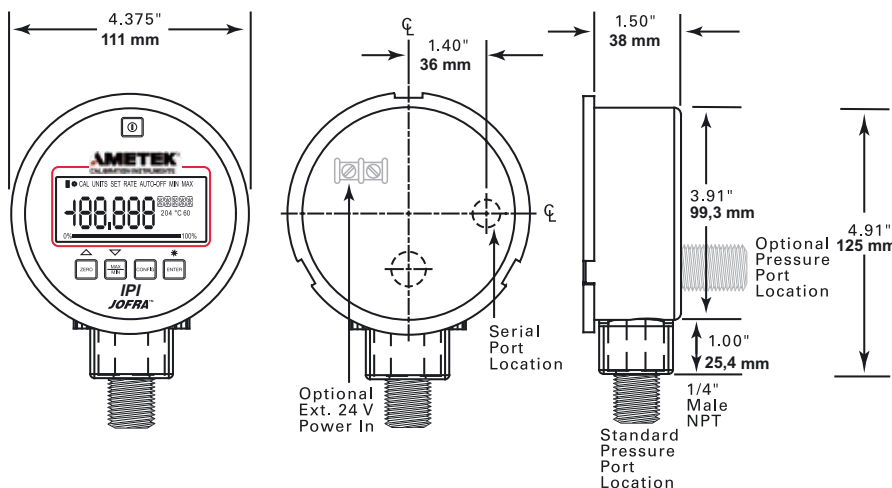



JOFRA IPI FEATURES

The JOFRA IPI was engineered to be a natural replacement for analog gauges. This instrument offers the user the familiarity of a round shape with the technology of a digital pressure sensor and readout. Additionally, helpful features were added to extend the usefulness of this line of indicators.

Display

The IPI display does more than just show a pressure reading. The user can check temperature and exact battery voltage through the use of the keypad. The large, 5 1/2 digit, 0.65 in (1.65 cm) character display is large and easy-to-read; even from a distance. Icons are also included to indicate battery life, engineering units, and there is a bar graph that shows the percentage of scale reading. All of this information can be read in low light with the use of the backlight.

Battery operation

One thing that you should not have to worry about is the battery life of this indicator. The lone drawback of an electronic pressure device is that it requires power to give you a reading. We thought about this and designed a circuit that provides excellent long life for the battery supply. Additionally, we installed user options that allow you to further conserve the energy: Auto-shutoff, selectable sampling rate, and the backlight.

You can control the battery life by selecting a mix of settings that meet your measurement needs and also contribute to having a dependable power supply. For example, you may need constant indication in low light; in which case the auto-shutoff would be turned off and the backlight would be on. This would drop the battery life to approximately 150 hours: still plenty of time to collect several shifts worth of data. Alternatively, you may not need those features and you may only need to have a sample taken every so often. In that case, you can increase the battery lifetime to approximately 2,000 hours.

Auto shutoff

The IPI is delivered with the auto-shutoff active and set to 30 minutes: like many of our other instruments. This feature can be reduced from 30 minutes down to 1 minute in 1 minute increments. In cases where a constant reading is necessary, this can also be turned completely off to allow for continuous operation.

Sampling rate

The IPI sampling rate is user selectable to meet your application. You may want to capture fast system transients and require a fast sampling rate; you can set the IPI to take a reading 10 times per second. Conversely, you may want to conserve battery life and only need periodic samples. In this case, you can select 1 sample per every 2 seconds. With this setting, the IPI holds its display reading between samples and is essentially in a "sleep" mode allowing for a battery life up to 2,000 hours: this works well for in process and panel mounted applications. You can also choose the accepted instrument sampling rate of 3 samples per second for normal use or to allow for filtering, you can select 1 sample per second. The IPI is flexible enough for most of your pressure measurement scenarios.

Damping adjustment

The damping function can be turned on or off on the IPI. This feature allows for readings to be integrated which accounts for momentary changes such as those from pulsing sources.

MIN/MAX

As mentioned above, you may be looking for the transient in your process. With the proper sampling rate set, you need to be sure that the indication is updated and that you do not miss the reading. No worry! The IPI offers you the ability to check the minimum and maximum readings during the transient.

Custom engineering unit

In addition to the 18 available engineering units on the IPI, you can create your own unit to meet your measurement need. For example, if you need to take a level measurement, simply determine the pressure that equates to one unit of that measurement and set that as your engineering unit. The application may require gallons, feet, inches, meters, liters, or similar; with the IPI you can take the measurement.

Tare

Beyond zeroing the IPI, you may have to account for residual pressure. The Tare feature allows you to take care of that error and prevent the manual calculation of the difference. This can be used in combination with the custom engineering units to make the level measurements much easier.

Temperature display and compensation

Because the IPI is designed for in-process tasks, temperature compensation is included to make the job easier. This allows the IPI to maintain accuracy over the measurement range. You can also check the measured temperature from the keypad.

Serial communications

The IPI has a serial port that is accessible through the back of the case. This feature uses standard ASCII commands to allow for extraction of data from the IPI while taking readings. This requires the optional serial cable.

Field recalibration

The IPI does not need to be returned to the factory for calibration. If you have a reliable and accurate pressure reference or a local laboratory, you may re-calibrate the IPI locally. This feature is password protected.

In-process indicator

You can use the IPI as your in-process pressure indicator. The IPI is an optimal device for this application. You can select the sampling rate to extend your battery life; or use the external power supply option to allow for continuous readings without the need for battery replacement.

The IPI offers a higher accuracy than analog process gauges. With the backlit display, it is easier to read as well. You can also access the temperature; something that you cannot read on a standard process gauge. The bar graph provides a quick indication of the percentage of scale reading allowing for a rapid assessment of system conditions.

Hazard location information

An Ex-hazardous area refers to an area made hazardous by the potential presence of flammable or explosive vapors. These areas are also referred to as hazardous locations, see NFPA 70, Article 500 or CSA C22.1 Section 18.

The IPI Industrial Pressure Indicator is certified by CSA as conforming to relevant Canadian and USA standards with the following rating: Class 1, Div. 2, Groups A-D.

JOFRA IPI OPTIONS

Protective boot

All IPI indicators in a standard configuration are supplied with a protective boot; this includes those supplied in System configurations.

The boot is not supplied with units that are purchased with the 24 VDC power supply option and/or the back mount option.

The boot can be deducted from the standard delivery of indicators at the customer request.

External power

Sometimes it is more convenient to take advantage of an existing power source rather than using batteries. The IPI may be ordered with a 24 VDC power supply option. The unit has terminals to accept the positive and negative leads to allow for easy connection to the power supply.

These units will not be supplied with batteries and batteries should not be installed when the unit is connected to 24 VDC power.

Back mounting option

The IPI may be ordered with a back mounting configuration. This design has the 1/4 in. NPT male connection on the back of the case vice the lower manifold connection. This allows for use in panel mounted applications or in applications where flat mounting is necessary such as in an overhead.

This configuration is not delivered with a protective boot.

Systems

Our goal is to provide solutions to the user. We offer the IPI in six different systems. Each system is delivered in a carrying case, with the IPI and a pressure source.

These systems are available with all ranges and offer pressure sources from vacuum pneumatic handpumps to hydraulic pumps that can generate in excess of 10,000 psi (700 bar). If you need to have a portable test kit, the IPI System will meet your needs.

ORDERING INFORMATION - IPI INDICATOR ONLY

Order No. Description

	Pressure indicator – 1st through 3rd characters
IPI	Industrial Pressure Indicator
	Indicator pressure range – 4th through 7th characters
030C	Vacuum to 30 psi (2 bar)
100C	Vacuum to 100 psi (7 bar)
300C	Vacuum to 300 psi (21 bar)
500C	Vacuum to 500 psi (35 bar)
015G	0 to 15 psi (1 bar)
01KG	0 to 1,000 psi (70 bar)
02KG	0 to 2,000 psi (140 bar)
03KG	0 to 3,000 psi (200 bar)
05KG	0 to 5,000 psi (350 bar)
10KG	0 to 10,000 psi (700 bar)
	Boot – 8th character
B	With boot (standard delivery for indicator with battery power and lower mounting – and on all system kits)
X	No boot (standard delivery for indicators with back mounting and/or 24 VDC powers supply connection)
	Power supply – 9th character
X	Batteries (standard)
E	Connection for external 24 VDC power supply
	Mounting – 10th character
X	Lower mount (standard)
B	Back mount
	Base model number – 11th through 13th characters
IND	IPI indicator only with standard accessories for configuration
	Certification – 14th character
G	NIST traceable certificate (standard)
H	Accredited certificate (optional – on quotation basis)
	Sample order number
IPI030CBXXINDG	IPI 30 psi (2 bar) indicator with boot, standard accessories, and NIST traceable calibration certificate.

JOFRA™ IPI Series

Industrial Pressure Indicator System A

- Vacuum to 0 psi (0 bar)
- 0 to 15 psi (1 bar)
- 0 to 30 psi (2 bar)
- 0 to 100 psi (7 bar)
- 0 to 300 psi (21 bar)



This system includes the JOFRA IPI indicator together with one of the following pneumatic hand pumps: T-730, T-740 or T-750, depending on the chosen pressure range and options.

System A is an easy-to-use single-hand operated test system.

The System A comes in a protective carrying case with cutouts for fittings, hose, and the complete assembled test unit - no time is required to assemble the unit every time you need it. The indicator can at any time be used separately for other pressure test tasks. A swivel fitting between the pump and the indicator makes it possible to adjust the indicator for easy viewing.

All IPI indicators used in System A are delivered calibrated in both pressure and vacuum. If a combination pump is required see System B.

T-700 series pneumatic handpumps

This handpump is used in the IPI System A. Three pump models are available, each covering a specific pressure range.

The pump features a built-in vent valve, a vernier valve for fine adjustment, and dual pressure output. There is an easy connection between the pump and the calibrator.



Pressure range, T-730	0 to 30 psi / 0 to 2 bar
Pressure range, T-740	0 to 300 psi / 0 to 21 bar
Pressure range, T-750	25 to 0 inHg / -0.850 to 0 bar
Test medium	Air
Wetted parts	Aluminum, brass, stainless steel, nylon, Nylatron GS
Connections to test object	24 in / 0.6 m hose with 1/4" NPT female terminations and BSP adapter

Part No.	Description
T-730	Pump: 0 to 30 psi (0 to 2 bar)
T-740	Pump: 0 to 300 psi (0 to 21 bar)
T-750	Pump: -25 to 0 inHg (-0.850 to 0 bar)

Accessories

Part No.	Description
65R191	Fitting set BSP female: 1x1/8" 1x3/8" 1x1/2" teflon tape and packings (60R191)
65R192	Fitting set NPT female: 1x1/8" 1x1/4" 1x3/8" 1x1/2" teflon tape and packings (60R191)
60I104	Roll of teflon tape
123958	Serial communication cable for PC
T-746	Service kit for T-730 and T-740
T-747	Service kit for T-750 pump

Standard delivery:

IPI indicator:

- Calibration certification for pressure and vacuum performance traceable to NIST
- (3) AA batteries
- Adapter to 1/4" BSP male
- User manual
- Protective boot

Also included with System A delivery:

- Handpump T-730 for ranges to 30 psi (2 bar)
- Handpump T-740 for 300 psi (21 bar) range
- Handpump T-750 for 15 psi (1 bar) range with vacuum selection
- 24 in (0.6 m) hose for pump with 1/4" NPT female termination and 1/4" BSP adapter fitting
- Swivel fitting on pump
- 1 roll of Teflon tape
- Protective carrying case

Shipping information

Weight 12.13 lb / 5.5 kg
 Size..... 7.4 x 13.8 x 22 in / 188 x 350 x 560 mm

Ordering information IPI System A

Order no. Description

	Pressure indicator – 1st through 3rd characters
IPI	Industrial Pressure Indicator
	Indicator pressure range – 4th through 7th characters
030C	Vacuum to 30 psi (2 bar)
100C	Vacuum to 100 psi (7 bar)
300C	Vacuum to 300 psi (21 bar)
015G	0 to 15 psi (1 bar)
	Boot – 8th character
B	With boot (standard delivery for indicator with battery power and lower mounting – and on all system kits)
	Power supply – 9th character
X	Batteries (standard)
	Mounting – 10th character
X	Lower mount (standard)
	Base model number – 11th through 13th characters
AXX	IPI test System A with pneumatic pressure handpump
AVX	IPI test System A with pneumatic vacuum handpump (30 psi (2 bar) range only)
	Certification – 14th character
G	NIST traceable certificate (standard)
H	Accredited certificate (optional – on quotation basis)
	Sample order number
IPI030CBXXAXXG	IPI 30 psi (2 bar) indicator with boot and in pressure test System A kit with pneumatic pressure handpump and NIST traceable calibration certificate

JOFRA™ IPI Series

Industrial Pressure Indicator System B

- Vacuum to 300 psi (21 bar)
- Vacuum to 500 psi (35 bar)

This system includes a dual function pneumatic hand pump. With this pump you can generate both vacuum and pressure for your applications. It takes just a few seconds to switch between vacuum and pressure, just push one button (valve) on the T-930 handpump.

The System B comes in a protective carrying case with cutouts for fittings, hose and the complete assembled test unit - no time required to assemble the unit every time.



Standard delivery:

IPI indicator:

- Calibration certification for pressure and vacuum performance traceable to NIST
- (3) AA batteries
- Adapter to 1/4" BSP male
- User manual
- Protective boot

Also included with System B delivery:

- Handpump T-930 for all ranges
- 40 in (1 m) hose for pump with 1/4" NPT female fitting and 1/4" BSP fitting
- 1 roll of Teflon tape
- Protective carrying case

Shipping information

Weight..... 12.13 lb / 5.5 kg
 Size.....7.4 x 13.8 x 22 in / 188 x 350 x 560 mm

T-930 hand pump

The T-930 pump is an easy-to-use single hand-operated pneumatic pump. The T-930 pump features both vacuum and pressure generation up to 500 psi (35 bar).

One button (valve) makes it easy to switch from vacuum to pressure measurements. Built-in release valve, vernier valve for fine adjustment and dual pressure output enable safe and simple operation.



Pressure range..... -14 psi to 500 psi / -0.95 to 35 bar
 Test medium..... Air
 Wetted parts.....Anodized aluminum, nickel-plated brass, stainless steel, Nylon
 Connections to test object:Hose 40 in / 1 m with 1/4" BSP and NPT female terminations

Part No.	Description
T-930	Pump: -0.95 to 35 bar / -28 inHg to 500 psi

Accessories

Part No.	Description
65R191	Fitting set BSP female: 1x1/8" 1x3/8" 1x1/2" teflon tape and packings (60R191)
65R192	Fitting set NPT female: 1x1/8" 1x1/4" 1x3/8" 1x1/2" teflon tape and packings (60R191)
60I104	Roll of teflon tape
123958	Serial communication cable for PC
75P013	Service kit for T-930 pump

Ordering information IPI System B

Order No. Description

Order No.	Description
IPI	Pressure indicator - 1st through 3rd characters Industrial Pressure Indicator
300C	Indicator pressure range - 4th through 7th characters Vacuum to 300 psi (21 bar)
500C	Vacuum to 500 psi (35 bar)
B	Boot - 8th character With boot (standard delivery for indicator with battery power and lower mounting – and on all system kits)
X	Power supply - 9th character Batteries (standard)
X	Mounting - 10th character Lower mount (standard)
BXX	Base model number - 11th through 13th characters IPI test System B with combination pneumatic handpump
G	Certificate - 14th character NIST traceable certificate (standard)
H	Accredited certificate (optional – on quotation basis)

IPI300CBXXBXXG **Sample order number**
 IPI 300 psi (21 bar) indication with boot and in pressure test System B kit with pneumatic combination handpump and NIST traceable calibration certificate.

JOFRA™ IPI Series

Industrial Pressure Indicator System C

- 0 to 500 psi (35 bar)
- 0 to 1,000 psi (70 bar)
- 0 to 2,000 psi (140 bar)
- 0 to 3,000 psi (200 bar)
- 0 to 5,000 psi (350 bar)

This system consists of an IPI indicator together with a hydraulic, high pressure hand pump T-620 or T-620H, which features an oil reservoir to prime the system.

System C is an easy-to-use single-hand operated test system. No need for a flat surface (table) to operate the system. The system includes release valve and vernier valve for fine adjustment to enable safe and simple operation of the pump.

The System C comes in a protective carrying case with cutouts for fittings, hose, and the complete assembled test unit - no time adder to assemble the unit every time. Easy and fast connection between pump and indicator makes it easy to use the pressure indicator separately for other pressure test tasks.



Standard delivery:

IPI indicator:

- Calibration certification for pressure performance traceable to NIST
- (3) AA batteries
- Adapter to 1/4" BSP male
- User manual
- Protective boot

Also included with System C delivery:

- Handpump T-620 for ranges to 3,000 psi (200 bar)
- Handpump T-620H for 5,000 psi (350 bar) range
- 20 in (0.5 m) hose for pump with 1/4" NPT female fitting and 1/4" BSP fitting
- 1 roll of Teflon tape
- Protective carrying case

Shipping information

Weight 12.13 lb / 5.5 kg
 Size 7.4 x 13.8 x 22 in / 188 x 350 x 560 mm

AMETEK hydraulic handpump

This easy-to-use hand pump is specially designed for high pressure applications. The pump is used in the IPI system C.

The pump has a 0.5 pint / 200 ml built-in reservoir, vent valve, and vernier valve for fine adjustment. The pump has a dual pressure output - one for the test object and one for the IPI indicator.



Pressure range, T-620 0 to 3,000 psi / 200 bar
 Pressure range, T-620H 0 to 5,000 psi / 350 bar
 Test medium.....Hydraulic oil
 Wetted parts..... Aluminum, brass, stainless steel, Lexan
 Connection to test object:.....Hose 20 in / 0.5 m with 1/4" NPT female terminations and BSP adapter

Part No.	Description
T-620	Pump: 0 to 3,000 psi (200 bar)
T-620H	Pump: 0 to 5,000 psi (350 bar)

Accessories

Part No.	Description
65P175	3 ft. (1 m) hose with 1/4" BSP female termination Max. pressure 5,000 psi (350 bar)
65P180	6.6 ft. (2 m) hose with 1/4" BSP female termination Max. pressure 5,000 psi (350 bar)
T-656	Service kit for pump
123958	Serial communication cable for PC
60I104	Teflon tape

Ordering information IPI System C

Order No. Description

Order No.	Description
IPI	Industrial Pressure Indicator
	Pressure indicator- 1st through 3rd characters
	Indicator pressure range - 4th through 7th characters
500C	Vacuum to 500 psi (35 bar)
01KG	0 to 1,000 psi (70 bar)
02KG	0 to 2,000 psi (140 bar)
03KG	0 to 3,000 psi (200 bar)
05KG	0 to 5,000 psi (350 bar)
	Boot - 8th character
B	With boot (standard delivery for indicator with battery power and lower mounting – and on all system kits)
	Power supply - 9th character
X	Batteries (standard)
	Mounting - 10th character
X	Lower mount (standard)
	Base model number - 11th through 13th characters
CXX	IPI test system C with hydraulic pressure handpump
	Certificate - 14th character
G	NIST traceable certificate (standard)
H	Accredited certificate (optional – on quotation basis)

IPI01KGBXXCXXG

Sample order number

IPI 1,000 psi (70 bar) indicator with boot and in pressure test System C with hydraulic pressure handpump and NIST traceable calibration certificate.

JOFRA™ IPI Series

Industrial Pressure Indicator System D

- 0 to 500 psi (35 bar)
- 0 to 1,000 psi (70 bar)
- 0 to 2,000 psi (140 bar)
- 0 to 3,000 psi (200 bar)
- 0 to 5,000 psi (350 bar)

This system consists of an IPI indicator together with a rugged, hydraulic, high pressure screw pump.

System D is an easy-to-use test system. Place the pump on a flat surface and turn the handle to generate pressure. You can adjust the indicator to fit the best viewing angle. The system includes a manifold for connection of the test device, a fine adjustment vernier valve (optional), and a reservoir for extra oil or water (optional).

The System D comes in a protective carrying case with cutouts for fittings and the complete assembled test unit - no time adder to assemble the unit every time. Easy and fast connection between pump and indicator makes it easy to use the pressure calibrator separately for other pressure test tasks.



Standard delivery:

IPI indicator:

- Calibration certification for pressure performance traceable to NIST
- (3) AA batteries
- Adapter to 1/4" BSP male
- User manual
- Protective boot

Also included with System D delivery:

- Screw pump 65-P016 for hydraulic oil
- Screw pump 65-P017 for water
- 1 roll of Teflon tape
- 10 bonded seals
- 6 mm Allen key
- Protective carrying case

Shipping information

Weight26.5 lb / 12 kg
 Size.....9.1 x 17.3 x 29.5 in / 230 x 440 x 750 mm

AMETEK screw pump

The AMETEK screw pump is designed for very easy generation of high pressure.

This pump is part of system D. The screw pump has a 4 connection manifold. Fine adjustment, vernier valve, liquid reservoir, and fittings are optional. The AMETEK screw pump may be delivered for 2 different test media: hydraulic oil or water.



Pressure range..... 0 to 5,000 psi / 350 bar
 Test media.....Hydraulic oil, water
 Wetted parts..... Aluminum, brass, stainless steel
 Connections to test objects: 4 x 1/4" BSP female

Part No.	Description
65-P016	Screw pump oil: 0 to 5000 psi (350 bar) ¹⁾
65-P017	Screw pump water: 0 to 5000 psi (350 bar) ¹⁾
	¹⁾ 0.85 oz (25 ml) reservoir

Accessories

Part No.	Description
65P175	3.3 ft. (1 m) hose with 1/4" BSP female termination Max. pressure 5,000 psi (350 bar)
65P180	6.6 ft. (2 m) hose with 1/4" BSP female termination Max. pressure 5,000 psi (350 bar)
60I156	4.9 ft. (1.5 m) hose with 1/4" BSP female termination Max. pressure 10,000 psi (700 bar)
60I157	16.4 ft. (5 m) hose with 1/4" BSP female termination Max. pressure 10,000 psi (700 bar)
65N000	Extension tube, 4.72 in (20 mm)
65-R975	10.14 oz (300 ml) reservoir set including valve and .. bonded seals
60R135	Valve for reservoir
60P013	Vernier valve for fine adjustment
123958	Serial communication cable for PC
50-REP-615	Quick connector set (male + female) Max. pressure 10,000 psi (700 bar)
SPK-HPC-004	Complete banjo/instrument connecting set
60I104	Teflon tape

Ordering information IPI System D

Order No. Description

Order No.	Description
IPI	Industrial Pressure Indicator
	Pressure indicator- 1st through 3rd characters
	Indicator pressure range - 4th through 7th characters
500C	Vacuum to 500 psi (35 bar)
01KG	0 to 1,000 psi (70 bar)
02KG	0 to 2,000 psi (140 bar)
03KG	0 to 3,000 psi (200 bar)
05KG	0 to 5,000 psi (350 bar)
	Boot - 8th character
B	With boot (standard delivery for indicator with battery power and lower mounting – and on all system kits)
	Power supply - 9th character
X	Batteries (standard)
	Mounting - 10th character
X	Lower mount (standard)
	Base model number - 11th through 13th characters
DOX	IPI test System D with hydraulic oil screw pump
DWX	IPI test System D with water screw pump
	Certificate - 14th character
G	NIST traceable certificate (standard)
H	Accredited certificate (optional – on quotation basis)
IPI01KGBXXDOXG	Sample order number
	IPI 1,000 psi (70 bar) indicator with boot and in pressure test System D kit with hydraulic oil screw pump and NIST traceable calibration certificate.

JOFRA™ IPI Series

Industrial Pressure Indicator System E

- 0 to 1,000 psi (70 bar)
- 0 to 2,000 psi (140 bar)
- 0 to 3,000 psi (200 bar)
- 0 to 5,000 psi (350 bar)
- 0 to 10,000 psi (700 bar)



This system consists of an IPI indicator together with a rugged, hydraulic, high pressure pump.

System E is an easy-to-use test system. The hydraulic pump makes it very easy to prime the system. You can adjust the indicator to fit the best viewing angle. The system includes a manifold for connection of two test devices and the fine adjustment vernier valve is standard.

The System E comes in a protective carrying case with cutouts for fittings and the complete assembled test unit - no time adder to assemble the unit every time. Easy and fast connection between pump and indicator makes it easy to use the pressure calibrator separately for other pressure test tasks.

AMETEK high pressure hydraulic oil pump

The AMETEK hydraulic pump is designed for high pressure applications. The pump is used in the IPI System E.

The pump has a 4 connection output manifold. Fine adjustment vernier valve and fittings are optional.



Pressure range..... 0 to 10,000 psi / 700 bar
 Test media..... oil
 Wetted parts..... Aluminum, brass, stainless steel
 Connections to test objects: 4 x 1/4" BSP female

Part No.	Description
65-P014	Hydraulic pump for oil: 0 to 10,000 psi (700 bar) ¹⁾ 1) 15.22 oz (450 ml) reservoir

Accessories

Part No.	Description
60I156	4.9 ft. (1.5 m) hose with 1/4" BSP female termination Max. pressure 10,000 psi (700 bar)
60I157	16.4 ft. (5 m) hose with 1/4" BSP female termination Max. pressure 10,000 psi (700 bar)
123958	Serial communication cable for PC
50-REP-615	Quick connector set (male + female) Max. pressure 10,000 psi (700 bar)
SPK-HPC-004	Complete banjo/instrument connecting set
60P013	Vernier valve for fine adjustment
60I104	Teflon tape
60R120	1/4" bonded seal
11-90109	1/4" BSP male to 1/4" NPT female

Standard delivery:

IPI indicator:

- Calibration certification for pressure performance traceable to NIST
- (3) AA batteries
- Adapter to 1/4" BSP male
- User manual
- Protective boot

Also included with system D delivery:

- Hydraulic pump 65-P014 for hydraulic oil
- Vernier valve
- 1 roll of Teflon tape
- 5 bonded seals
- 6 mm Allen key
- Protective carrying case

Shipping information

Weight 28.7 lb / 13 kg
 Size 9.1 x 17.3 x 29.5 in / 230 x 440 x 750 mm

Ordering information IPI System E

Order No. Description

Order No.	Description
IPI	Industrial Pressure Indicator
	Pressure indicator - 1st through 3rd characters
	Indicator pressure range - 4th through 7th characters
01KG	0 to 1,000 psi (70 bar)
02KG	0 to 2,000 psi (140 bar)
03KG	0 to 3,000 psi (200 bar)
05KG	0 to 5,000 psi (350 bar)
10KG	0 to 10,000 psi (700 bar)
	Boot - 8th character
B	With boot (standard delivery for indicator with battery power and lower mounting – and on all system kits)
	Power supply - 9th character
X	Batteries (standard)
	Mounting - 10th character
X	Lower mount (standard)
	Base model number - 11th through 13th characters
EXX	IPI test System E with high pressure pump for hydraulic oil
	Certificate - 14th character
G	NIST traceable certificate (standard)
H	Accredited certificate (optional – on quotation basis)
IPI01KGBXXEXXG	Sample order number IPI 1,000 psi (70 bar) indicator with boot an in pressure test system System E kit with high pressure pump for hydraulic oil and NIST traceable calibration certificate.

JOFRA™ IPI Series

Industrial Pressure Indicator System F

- 0 to 500 psi (35 bar)
- 0 to 1,000 psi (70 bar)
- 0 to 2,000 psi (140 bar)
- 0 to 3,000 psi (200 bar)
- 0 to 5,000 psi (350 bar)
- 0 to 10,000 psi (700 bar)



System F is an easy-to-use test system. The hydraulic pump makes it very easy to prime the system. The pump contains 75 in³ / 1.23 l of liquid.

The system includes a manifold for connection of two test devices and the fine adjustment vernier valve is standard. The System F comes in a protective carrying case with cutouts for fittings. Easy and fast connection between pump and calibrator makes it easy to use the pressure calibrator separately for other pressure test tasks.

AMETEK Type T hydraulic oil or water pump

The type T pump is designed for high pressure applications up to 15,000 psi (1,000 bar).



The pump and system may be ordered with either oil or a water/alcohol mixture as the pressure medium. The pump is constructed of 300 series stainless steel and Monel allowing for the use of other hydraulic media. There are three available seal packages for the system: Buna-N, Viton®, and EPT. 1)

The Type T pump features a dual pressure output manifold, fine adjustment vernier valve, relief valve, and dual volume control for rapid pressure increase at lower pressures and easier pumping at higher pressures.

1) Customer must verify compatibility of seals and pump materials with pressure medium. Viton is a registered trademark.

Pressure range..... 15,000 psi / 0 to 1,000 bar
 Test media.....Hydraulic oil, water, Skydrol
 Wetted part.....Stainless steel, Monel
 Connections to test objects BSP fittings 1/4" and 1/2" female;
 PT fittings 1/4" and 1/2" female

Part No.	Description	Seals
T-1	Pump: 0 to 15,000 psi (1,000 bar) water	- Buna N 2)
T-1/VITON	Pump: 0 to 15,000 psi (1,000 bar) water	- Viton
T-1/EPT	Pump: 0 to 15,000 psi (1,000 bar) water	- EPT
T-1/OIL	Pump: 0 to 15,000 psi (1,000 bar) oil	- Buna N 2)
T-1/OIL/VITON	Pump: 0 to 15,000 psi (1,000 bar) oil	- Viton
T-1/OIL/EPT	Pump: 0 to 15,000 psi (1,000 bar) oil	- EPT

2) Standard

Accessories

Part No.	Description
601156	4.9 ft. (1.5 m) hose with 1/4" BSP female termination Max. pressure 10,000 psi (700 bar)
601157	16.4 ft. (5 m) hose with 1/4" BSP female termination Max. pressure 10,000 psi (700 bar)
123958	Serial communication cable for PC
T-786	1/4" NPT male to 1/4" BSP female
T-787	1/4" NPT male to 1/2" BSP female
60R120	1/4" bonded seal

Standard delivery:

IPI indicator:

- Calibration certification for pressure performance traceable to NIST
- (3) AA batteries
- Adapter to 1/4" BSP male
- User manual
- Protective boot

Also included with system F delivery:

- Type T Hydraulic pump
 - T-1 for T pump with water/alcohol and Buna seals
 - T-1/VITON for T pump with water/alcohol and Viton seals
 - T-1/EPT for T pump with water/alcohol and EPT seals
 - T-1/OIL for T pump with oil and Buna seals
 - T-1/OIL /VITON for T pump with oil and Viton seals
 - T-1/OIL /EPT for T pump with oil and EPT seals
- 1 roll of Teflon tape
- Protective carrying case

Shipping information

Weight 39.7 lb / 18 kg
 Size 9.1 x 17.3 x 29.5 in / 230 x 440 x 750 mm

Ordering information IPI System F

Order No. Description

Order No.	Description
IPI	Industrial Pressure Indicator
	Pressure indicator - 1st through 3rd characters
	Indicator pressure range - 4th through 7th characters
500C	Vacuum to 500 psi (35 bar)
01KG	0 to 1,000 psi (70 bar)
02KG	0 to 2,000 psi (140 bar)
03KG	0 to 3,000 psi (200 bar)
05KG	0 to 5,000 psi (350 bar)
10KG	0 to 10,000 psi (700 bar)
	Boot - 8th character
B	With boot (standard delivery for indicator with battery power and lower mounting – and on all system kits)
	Power supply - 9th character
X	Batteries (standard)
	Mounting - 10th character
X	Lower mount (standard)
	Base model number - 11th through 13th characters
FWB	IPI test System F - water - seals: Buna N
FWV	IPI test System F - water - seals: Viton
FWE	IPI test System F - water - seals: EPT
FOB	IPI test System F - oil - seals: Buna N
FOV	IPI test System F - oil - seals: Viton
FOE	IPI test System F - oil - seals: EPT
	Certificate - 14th characters
G	NIST traceable certificate (standard)
H	Accredited certificate (optional – on quotation basis)

IPI10KGBXXFOEG

Sample order number

IPI 10,000 psi (700 bar) indicator with boot and in pressure test System F kit with Type T pump for oil, EPT seals and NIST traceable calibration certificate.

IPI INDICATOR PRESSURE RANGES

This table shows the resolutions that can be obtained by the IPI indicators throughout all engineering units.

Resolution obtained by the IPI indicator	IPI30C Vacuum to 30 psi Vacuum to 2 bar		IPI100C Vacuum to 100 psi Vacuum to 7 bar		IPI300G Vacuum to 300 psi Vacuum to 21 bar		IPI500G Vacuum to 500 psi Vacuum to 35 bar	
Imperial ranges								
psi	-12.000	30.000	-12.000	100.00	-12.000	300.00	-12.00	500.00
inH ₂ O@4°C	-332.17	830.42	-332.2	2768.1	-332.2	8304.2	-332	13840
inH ₂ O@20°C	-332.76	831.89	-332.7	2773.0	-332.7	8318.9	-333	13865
inH ₂ O@60°F	-332.50	831.24	-332.5	2770.8	-332.5	8312.4	-332	13854
ftH ₂ O@4°C	-27.681	69.202	-27.68	230.67	-27.68	692.02	-27.7	1153.4
ftH ₂ O@20°C	-27.730	69.324	-27.73	231.08	-27.73	693.24	-27.7	1155.4
ftH ₂ O@60°C	-27.708	69.270	-27.71	230.90	-27.71	692.70	-27.7	1154.5
inHg@0°C	-24.432	61.081	-24.43	203.60	-24.43	610.81	-24.4	1018.0
Torr	-620.6	1551.5	-620.6	5171.5	-620	15514	-621	25858
Metric ranges								
bar	-0.8300	2.0000	-0.8300	7.0000	-0.8300	21.000	-0.8300	35.000
mbar	-830.0	2000.0	-830.0	7000.0	-830.00	21000	-830	35000
kPa	-83.00	200.00	-83.00	700.00	-83.0	2100.0	-83.0	3500.0
kg/cm ²	-0.8464	2.0394	-0.8464	7.1380	-0.846	21.414	-0.846	35.690
cmH ₂ O@4°C	-846.4	2039.5	-846.4	7138.2	-846	21415	-846	35691
cmH ₂ O@20°C	-847.9	2043.1	-847.9	7150.8	-847	21452	-848	35754
mH ₂ O@4°C	-8.464	20.395	-8.464	71.382	-8.46	214.15	-8.46	356.91
mH ₂ O@20°C	-8.479	20.431	-8.479	71.508	-8.48	214.52	-8.48	357.54
mmHg@0°C	-622.6	1500.1	-622.6	5250.4	-622	15751	-623	26252

Resolution obtained by the IPI indicator	IPI015G 0 to 15 psi 0 to 1 bar	IPI01KG 0 to 1,000 psi 0 to 70 bar	IPI02KG 0 to 2,000 psi 0 to 140 bar	IPI03KG 0 to 3,000 psi 0 to 200 bar	IPI05KG 0 to 5,000 psi 0 to 350 bar	IPI10KG 0 to 10,000 psi 0 to 700 bar
Imperial ranges						
psi	15.000	1000.0	2000.0	3000.0	5000.0	10000
inH ₂ O@4°C	415.21	27681	55361	83042	N/A	N/A
inH ₂ O@20°C	415.95	27730	55459	83189	N/A	N/A
inH ₂ O@60°F	415.62	27708	55416	83124	N/A	N/A
ftH ₂ O@4°C	34.601	2306.7	4613.5	6920.2	11534	23067
ftH ₂ O@20°C	34.662	2310.8	4621.6	6932.4	11554	23108
ftH ₂ O@60°C	34.635	2309.0	4618.0	6927.0	11545	23090
inHg@0°C	30.540	2036.0	4072.1	6108.1	10180	20360
Torr	775.73	51715	N/A	N/A	N/A	N/A
Metric ranges						
bar	1.0000	70.000	140.00	200.00	350.00	700.00
mbar	1000.0	70000	N/A	N/A	N/A	N/A
kPa	100.00	7000.0	14000	20000	35000	70000
kg/cm ²	1.0197	71.380	142.76	203.94	356.90	713.80
cmH ₂ O@4°C	1019.7	71382	N/A	N/A	N/A	N/A
cmH ₂ O@20°C	1021.5	71508	N/A	N/A	N/A	N/A
mH ₂ O@4°C	10.197	713.82	1427.6	2039.5	3569.1	7138.2
mH ₂ O@20°C	10.215	715.08	1430.2	2043.1	3575.4	7150.8
mmHg@0°C	750.06	52504	N/A	N/A	N/A	N/A



AMETEK Calibration Instruments offers a complete range of calibration equipment for temperature, pressure, and signal - including calibration software.

JOFRA Temperature standards

Portable precision thermometer. Dry-block and liquid bath calibrators: 4 series, with more than 20 models - featuring speed, portability, accuracy and advanced documenting functions with JOFRACAL temperature calibration software.

JOFRA Pressure standards

Convenient electronic systems ranging from -1 to 700 bar (25 inHg to 10,000 psi) - multiple choices of pressure ranges, pumps and accuracies, fully temperature- compensated for problem-free and accurate field use.

JOFRA Signal calibration

Process signal measurement and simulation for easy control loop calibration and measurement tasks - from handheld field instruments for multi or single signals to laboratory reference level bench top instruments.

JOFRA / JF Marine Instruments

A complete range of calibration equipment for temperature, pressure and signal, approved for marine use under the brand name JOFRA and JF Instruments.

FP temperature sensors

A complete range of temperature sensors for industrial and marine use.

*...because calibration is
a matter of confidence*

AMETEK[®]
CALIBRATION INSTRUMENTS

AMETEK Calibration Instruments is one of the world's leading manufacturers and developers of calibration instruments for temperature, pressure and process signals as well as for temperature sensors both from a commercial and a technological point of view.

Headquarter:

AMETEK Denmark A/S
(Sales, Europe and the Middle East)
Gydevang 32-34 • 3450 Allerød • Denmark
Tel: +45 4816 8000 • ametek@ametek.dk

www.ametekcalibration.com
www.jofra.com

Information within this document is subject to change without notice.
©2005, by AMETEK, Inc., www.ametek.com. All rights reserved.

Pub code SS-CP-2179-US Issue 0608

Sales offices:

AMETEK T&C - Americas (Sales, The Americas)
Tel: +1 518 689 0222 • jofra.info@ametek.com

AMETEK Singapore Pte. Ltd. (Sales, Asia)
Tel: +65 6 484 2388 • aspl@ametek.com.sg

AMETEK Inc. Beijing Rep. Office (Sales, China only)
Tel: +86 10 8526 2111 • jofra@ametek.com.cn

AMETEK GmbH (Sales, Germany only)
Tel: +49 2159 91360 • info@ametek.de

AMETEK Lloyd Instruments (Sales, UK only)
Tel: +44 (0) 1489 486 404 • jofra@ametek.co.uk