

**Principle of Operation**

Liquid enters the precision metering insert containing the turbine rotor. The liquid pressure drives the turbine rotor rate of rotation proportional to the volumetric flow rate. The rotor's rotation is magnetically coupled to a hermetically sealed indicator or indicator/transmitter.



**Figure 1.** MTX-122 1" with totalizing register



**Figure 2.** WPX-222 2" with totalizing register



**Figure 3.** MTX-433 3/4" with totalizing register and standard calibrated contact closure

**Accessories**

- rate of flow indicators
- totalizers
- batch controllers

**Benefits**

Saves Space	Very compact size Lightweight
Flexible and Unique Design	Add pulse transmitters without downtime Modular construction allows ease of service and field repair Power not required for mechanical version
Reliable	Sealed register prevents condensation or fogging One internal moving part

**Technical Information**

**Functional Specifications**

Fluid Types	Liquid
Maximum Pressure	227 psig (15 bar)
Fluid Temperature	32° to 120° F (0° to 49° C) or 32° to 250° F (0° to 121° C)
Registration	U.S. Gallons
Outputs	See Table 1 and Table 2
Mechanical Register	<p>Non-resettable Total</p> <p>Magnetically coupled-direct reading</p> <p>Electronic transmitter with register option for MTX Series and WPX Model 210</p> <p>Magnetically coupled activated reed switch contact closure</p> <p>Reed switch rating: resistive - 3 Watts DC, 0.2 Amp 30 VDC max (Model 840)</p> <p>Pulse transmitter with register option for MTX Series and WPX Model 210</p> <p>Power Supply: 30 VDC max, 15-20 mA</p> <p>Signal Output: non-symmetrical square frequency pulse train equal to supply voltage (Model 860)</p> <p>Infra-red transmitter with register option for WPX Model 222 only</p> <p>Power Supply: 24 VDC max, 30 mA</p> <p>Signal Output: non-symmetrical square frequency pulse train equal to supply voltage (Model 573)</p>

**Performance Specifications**

Accuracy	± 1.0 % of rate
Repeatability	± 0.25 % of rate
Flow Turndown Ratio	see Table 1 or Table 2
Flow Range	see Table 1 or Table 2

**Physical Specifications**

<b>Materials of Construction</b>	
Case	¾"- 1½" Brass 2"-10" Epoxy coated cast iron
Measuring Chamber	<p>MTX cold water models: Polystyrol</p> <p>MTX hot water models: Noryl</p> <p>WPX cold water models: Polyphenylenoxide</p> <p>WPX hot water models: Polyethersulfone</p>
Rotor	<p>MTX cold water models: Polystyrol</p> <p>MTX hot water models: Noryl</p> <p>WPX cold water models: 2"-5" Polypropylene; 6"-10" Polystyrole</p> <p>WPX hot water models: 2"-2.5" Polyamid; 3"-10" Polyetherether ketone</p>
Flanges	Cast Iron for 2" to 10" size
O-ring seals	EPDM
Register Housing	Plastic, Bronze, Aluminum
<b>Connections &amp; Mountings</b>	
Mounting Positions	<p>MTX Series: Horizontal with register up</p> <p>WPX Series: Horizontal with register up or vertical</p> <p>Ensure meter remains full.</p>
Typical Straight Pipe Requirements	<p>Upstream: 5 x D</p> <p>Downstream: 3 x D</p>
Process Connections	<p>MNPT: ¾" to 1½" sizes</p> <p>Flange: 2" to 10" sizes</p>
Electrical Connection	<p>For optional reed switch (Model 840)</p> <p>MTX Series and WPX Model 210: for optional electronic pulse transmitter (Model 860)</p> <p>WPX Model 222: for optional infra-red transmitter (Model 573)</p>
Options	Digital pulse transmitters and reed switch contact closure

**Flow Ranges/Dimensions - MTX Series**

Water Flow Rates at Standard Conditions 60° F  
 Minimum and maximum flow rates to achieve accuracy

MODEL 122, 123		413, 433, 444		Optional Outputs		
Meter Size		Flow rates (GPM)		Contact Closure	Reed Switch Model 840	Pulse Transmitter Model 860
inch	min	max	gallons/contact	gallons/contact	full scale frequency(Hz)	pulses/gallon
3/4	1.0	20.0	1.0	10 or 100	Cold- 20.63/Hot-38.57	Cold-61.89/Hot-115.71
1	2.0	50.0	1.0	10 or 100	16.67	20.0
1 1/2	3.0	85.0	10.0	10 or 100	14.17	10.0
2	4.0	130.0	10.0	10 or 100	21.67	10.0

Table 1

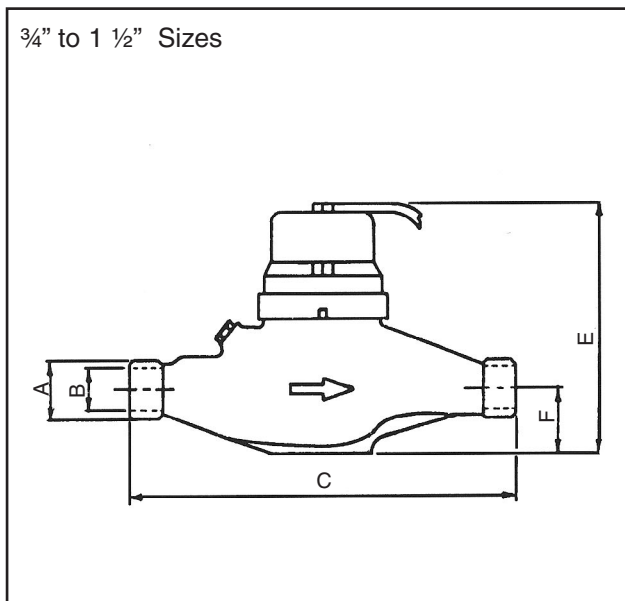

Figure 4

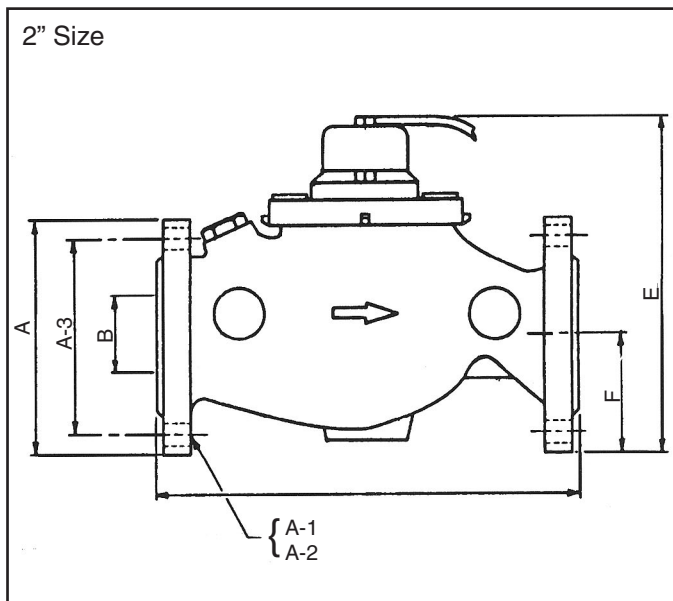

Figure 5

Sizes	3/4"	1"	1 1/2"	2"
Threads/flanges	1" NPT (25.4)	1 1/4" NPT (31.75)	2" NPT (50.80)	6 1/2" (165.10)
A-1 Bolt Holes #				4
A-2 Bolt Holes dia.				5/8" (15.88)
A-3 Bolt Holes dia.				4 3/4" (120.65)
B Bore dia.	3/4" Nominal	1" Nominal	1 1/2" Nominal	2" Nominal
C Length	7 1/2" (190.50)	10 1/2" (266.70)	12" (304.80)	10 3/4" (273.05)
D Width	3 3/4" (95.25)	4" (101.6)	5 1/2" (139.70)	6 1/2" (165.10)
E* Height	6" (152.40)	7 1/4" (184.15)	8 3/4" (222.25)	3 1/8" (79.37)
F Center line to base	1 1/4" (31.75)	1 1/2" (38.10)	1 3/4" (44.45)	3 1/8" (79.37)
Weight lbs. (kg)	4 1/2 lbs (2.04)	6 1/2 lbs. (2.9)	11 1/2 lbs. (5.2)	27 1/2 lbs. (12.5)

\*For 123/420 water meters add 1 1/2"

Table 2

inches (mm)

## Pressure Drop Curves

MTX Models 123, 414, 420, and 433

WPX Model 222

Sizes 3/4" to 10"

GPM	MTX Models				WPX Models					
	3/4"	1"	1.5"	2"	2"	3"	4"	6"	8"	10"
2	<.1									
3	0.11									
3.5	0.2				<i>* PSI Drops estimated from a logarithmic curve.</i>					
4.4	0.29	<.1								
6.6	0.58	0.2								
8.8	1	0.31	<.1							
13.2	2.5	0.725	0.28	<.1						
14.4	3.5	1	0.34	0.145						
17.6	4.35	1.45	0.435	0.21						
19.5	4.8	1.7	0.58	0.26						
22	7.1	2.3	0.725	0.29						
33		4.35	1.45	0.58						
44		7.5	2.9	1.2	<.1					
55		13	4.35	2	0.12					
66			5.8	2.9	0.145					
77			8.5	3.4	0.29					
88			12.5	4.35	0.33					
110				7.25	0.59	<.1	<.1	<.01		
132				10	0.725	0.16	0.12	0.0145		
154					1.1	0.22	0.2	0.02		
176					1.45	0.29	0.25	0.029		
198					1.85	0.435	0.36	0.04		
220					2.6	0.5	0.435	0.0435	<.01	
330					5.8	1.3	1.1	0.0725	0.02	
440					7.4	1.8	1.45	0.145	0.0435	<.01
660						2.9	2.7	0.29	0.072	0.02
880						7.25	6	0.6	0.145	0.043
1100							12	0.75	0.23	0.06
1320								1.3	0.3	0.08
1760								1.45	0.435	0.11
2200									0.85	0.27
3300									1.45	0.44
4400										0.8
	.75"	1.0"	1.5"	2"	2"	3"	4"	6"	8"	10"

Table 3

### Flow Ranges - WPX Model 222

Water Flow Rates at Standard Conditions 60° F  
Minimum and maximum flow rates to achieve accuracy

Meter Size	Flow Rates GPM		with Optional Outputs		
			Reed Switch Model 840	Infra-Red Transmitter Model 573	
	min	max	gallons/contact	full scale frequency	pulses/gallon
2"	4.40	396.00	10/100	66.00	10.00
3"	3.50	880.00	100/1000	14.70	1.00
4"	7.90	1321.00	100/1000	22.00	1.00
6"	17.60	1541.00	100/1000	25.70	1.00
8"	26.40	2862.00	100/1000	47.70	1.00
10"	88.00	5284.00	1000/10000	8.80	0.1

Table 4

### Dimensions - WPX Model 222

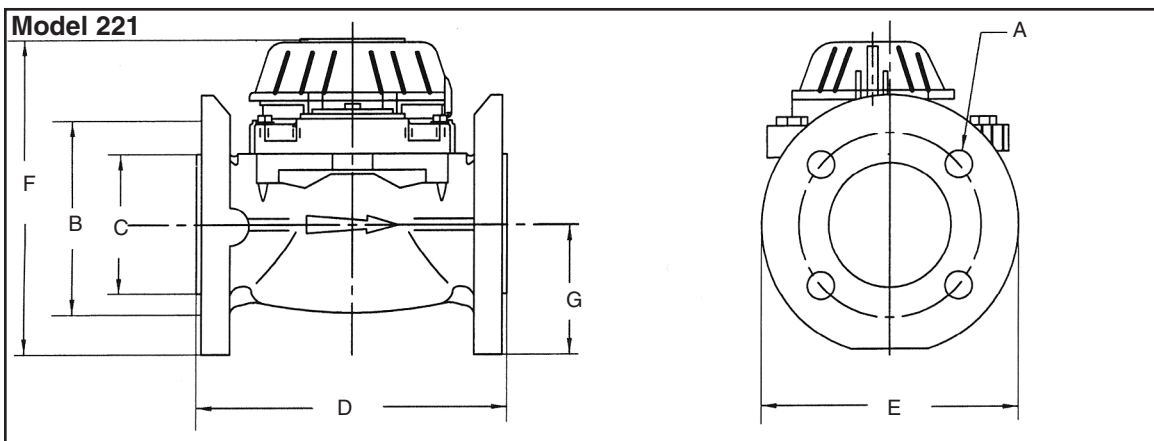

Figure 6

Size	2"		3"		4"	
Flange	6.50	(165.10)	7.87	(199.99)	8.66	(219.96)
Bolt holes #	4		4		8	
Bolt hole diameter A	0.63	(15.88)	0.63	(15.88)	0.63	(15.88)
Bore circle diameter B	4.75	(120.65)	6.00	(152.40)	7.50	(190.50)
Bore diameter C	2"	Nominal	3"	Nominal	4"	Nominal
Length D	7.87	(200)	8.86	(225)	9.84	(250)
Width E	6.10	(165)	7.87	(200)	8.66	(220)
Height F	7.80	(198)	9.57	(243)	10.20	(259)
Center to base line G	2.95	(75)	3.50	(89)	4.13	(105)
Weight lbs. (kg)	22.49	(10.2)	28.66	(13)	35.27	(16)

Size	6"		8"		10"	
Flange	11.22	(284.99)	13.40	(340.00)	16.00	(406.40)
Bolt holes #	8		8		12	
Bolt hole diameter A	0.75	(19.05)	0.75	(19.05)	0.88	(22.23)
Bore circle diameter B	9.50	(241.30)	11.75	(295)	14.25	(361.95)
Bore diameter C	6"	Nominal	8"	Nominal	10"	Nominal
Length D	11.81	(300)	13.78	(350)	17.72	(450)
Width E	11.22	(285)	13.39	(340)	15.94	(405)
Height F	14.96	(380)	16.06	(408)	17.13	(435)
Center to base line G	5.31	(135)	6.42	(163)	7.60	(193)
Weight lbs. (kg)	85.98	(39)	103.62	(47)	165.35	(75)

inches (mm)

Table 6

### Flow Ranges - WPX Model 210

Water Flow Rates at Standard Conditions 60° F  
Minimum and maximum flow rates to achieve accuracy

Meter Size	Flow Rates GPM		with Optional Outputs		
	min	max	Reed Switch Model 840 gallons/contact	Pulse Transmitter Model 860 full scale frequency	Pulse Transmitter Model 860 pulses/gallon
2"	8.00	305.00	10/100	50.83	10.00
3"	20.00	660.00	100/1000	22.00	2.00
4"	30.00	1100.00	100/1000	36.67	2.00
6"	45.00	1870.00	100/1000	31.17	1.00
8"	60.00	2860.00	100/1000	47.67	1.00
10"	80.00	4400.00	1000/10000	14.67	0.20

Table 5

### Dimensions - WPX Model 210

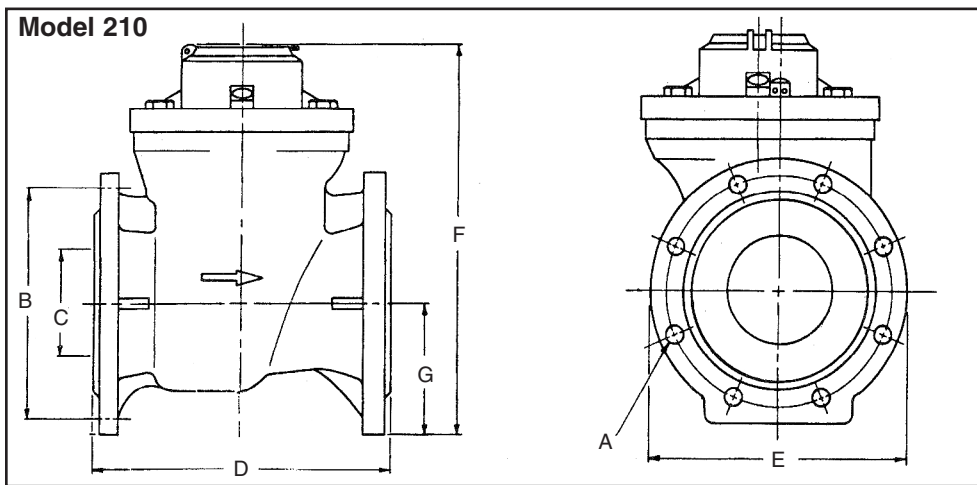

Figure 7

Size	2"		3"		4"	
Flange	6.50 (165.10)		7.87 (199.99)		8.66 (219.96)	
Bolt holes #	4		4		8	
Bolt hole diameter	A	0.63 (15.88)	A	0.63 (15.88)	A	0.63 (15.88)
Bore circle diameter	B	4.75 (120.65)	B	6.00 (152.40)	B	7.50 (190.50)
Bore diameter	C	2" Nominal	C	3" Nominal	C	4" Nominal
Length	D	7.87 (200)	D	8.90 (226.06)	D	9.80 (248.92)
Width	E	6.50 (165.10)	E	7.87 (199.99)	E	8.66 (219.96)
Height	F	10.80 (274.32)	F	11.50 (233.68)	F	12.20 (309.88)
Center to base line	G	2.95 (74.93)	G	3.70 (93.98)	G	4.17 (105.92)
Weight lbs. (kg)	22.50 (10.20)		31.00 (14.06)		42.80 (19.41)	

Size	6"		8"		10"	
Flange	11.22 (284.99)		13.40 (340)		16.00 (406.40)	
Bolt holes #	8		8		12	
Bolt hole diameter	A	0.75 (19.05)	A	0.75 (19.05)	A	0.88 (22.23)
Bore circle diameter	B	9.50 (241.30)	B	11.75 (295)	B	14.25 (361.95)
Bore diameter	C	6" Nominal	C	8" Nominal	C	10" Nominal
Length	D	11.80 (299.72)	D	13.78 (350)	D	17.70 (499.50)
Width	E	1.22 (284.99)	E	13.40 (340)	E	16.00 (406.40)
Height	F	14.25 (361.95)	F	15.30 (388.62)	F	17.44 (442.98)
Center to base line	G	5.30 (149.86)	G	6.40 (162.56)	G	8.00 (203.20)
Weight lbs. (kg)	71.65 (32.50)		99.00 (44.90)		238.00 (107.96)	

inches (mm)

Table 7

## Ordering Information

Please provide completed application data sheet (found at [www.aaliant.com](http://www.aaliant.com)) to allow us to confirm selection.

1. Confirm minimum and maximum flow ranges to maintain stated accuracy from Table 1 or Table 4 are within your requirements.
2. Select meter size.
3. Confirm pressure drop from Table 3.
4. Select flowmeter with register from below.

Part # \_\_\_\_\_

Part #	Description
<b>MTX</b>	
60480P001	3/4" Model 123, 120° F with totalizing register
60480P002	3/4" Model 122, 250° F with totalizing register
60480P009	3/4" Model 413, 250° F with totalizing register and contact closure
60480P013	3/4" Model 420, 120° F with totalizing register
60480P014	3/4" Model 421, 250° F with totalizing register
60480P037	3/4" Model 433, 120° F with totalizing register and contact closure
60480P041	3/4" Model 444, 250° F with totalizing register and contact closure
51260G038	1" x 3/4" 250° F Couplings set
60480P003	1" Model 123, 120° F with totalizing register
60480P004	1" Model 122, 250° F with totalizing register
60480P010	1" Model 413, 250° F with totalizing register and contact closure
60480P015	1" Model 420, 120° F with totalizing register
60480P016	1" Model 421, 250° F with totalizing register
60480P038	1" Model 433, 120° F with totalizing register and contact closure
51260G040	1-1/4" x 1" 250° F Couplings set
60480P005	1-1/2" Model 123, 120° F with totalizing register
60480P006	1-1/2" Model 122, 250° F with totalizing register
60480P011	1-1/2" Model 413, 250° F with totalizing register and contact closure
60480P017	1-1/2" Model 420, 120° F with totalizing register
60480P018	1-1/2" Model 421, 250° F with totalizing register
60480P039	1-1/2" Model 433, 120° F with totalizing register and contact closure
51260G025	2" x 1-1/2" 250° F Couplings set
60480P007	2" Model 123, 120° F with totalizing register
60480P008	2" Model 122, 250° F with totalizing register
60480P012	2" Model 413, 250° F with totalizing register and contact closure
60480P019	2" Model 420, 120° F with totalizing register
60480P020	2" Model 421, 250° F with totalizing register
60480P040	2" Model 433, 120° F with totalizing register and contact closure
60480P078	Model 840 calibrated contact closure (reed switch) (Models 420 & 421)
60480P236	Model 860 digital pulse transmitter
<b>WPX</b>	
60480P601	2" Model 222, 120° F with totalizing register
60480P600	2" Model 210, 250° F with totalizing register
60480P602	3" Model 222, 120° F with totalizing register
60480P601	3" Model 210, 250° F with totalizing register
60480P603	4" Model 222, 120° F with totalizing register
60480P602	4" Model 210, 250° F with totalizing register
60480P604	6" Model 222, 120° F with totalizing register
60480P603	6" Model 210, 250° F with totalizing register
60480P605	8" Model 222, 120° F with totalizing register
60480P604	8" Model 210, 250° F with totalizing register
60480P606	10" Model 222, 120° F with totalizing register
60480P605	10" Model 210, 250° F with totalizing register
60480P078	Model 840 calibrated contact closure (reed switch)
60480P236	Model 860 digital pulse transmitter (Model 210)
60480P608	Model 573 infra-red transmitter (Model 222 only)

## Options

- Digital pulse transmitters (Model 860)
- Reed switch contact closures (Model 840)
- Set of inlet/outlet couplings