

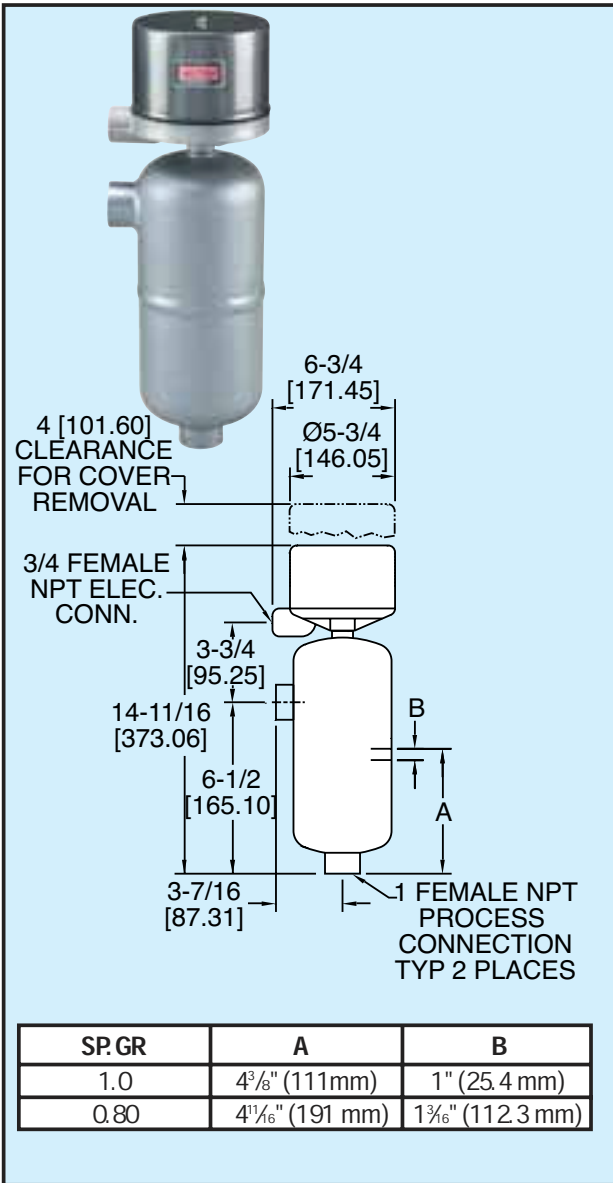

Series  
391

# Side Mounted-Chamber Type Level Control

## Compact, Low Cost, Hermetically Sealed Snap Switch Option



**Heavy duty and low cost** is the perfect description for the 391 Series level control. Stainless steel switching mechanism uses gravity return action instead of springs for long life. Weather-proof enclosure is standard. Welded steel chamber is good for 650 psig (45 bar) at 600°F (315°C).

### Applications

Oil refineries, chemical plants, power generating stations, pumping stations, heat transfer systems, sanitary/waste water facilities, drip legs, hydraulic systems, boilers.

### SPECIFICATIONS

**Service:** Compatible liquids.

**Wetted Materials:** Body: Carbon Steel. Float and Trim: 303 SS, 304 SS, 316 SS, and 430 SS.

**Temperature Limit:** Process: 600°F (315.6°C). Heat fins should be used for process temperatures above 500°F (260°C) with mercury switches, 400°F (204°C) with snap switches, and 350°F (176.7°C) with hermetically sealed snap switches.

**Pressure Limit:** 800 psig (55 bar) at 100°F (37.7°C), 650 psig (45 bar) at 600°F (315.6°C). Higher ratings available.

**Enclosure Rating:** NEMA 4X. Optional general purpose or explosion-proof.

**Switch Type:** SPDT snap switch, hermetically sealed snap switch or mercury switch. Optional DPDT.

**Electrical Rating:** Snap Switch: 12A @ 120 VAC, 5A @ 240VAC, 0.5A @ 125 VDC resistive, 0.25A @ 250 VDC resistive. Hermetically Sealed Snap Switch: 5A @ 125 VAC, 5A @ 240VAC, 5A @ 30VDC resistive. Mercury Switch: 4A @ 120 VAC/DC, 2A @ 240VAC/DC. Higher contact ratings available for the Mercury switch.

**Electrical Connections:** Screw terminal.

**Conduit Connection:** 3/4" female NPT.

**Process Connections:** 1" female NPT. Optional 1" socket weld hub or flange connections.

**Mounting Orientation:** Vertical.

**Weight:** 10 lb (4.5 kg)

**Agency Approvals:** UL.

**Specific Gravity:** 0.8 minimum. Optional 0.7 minimum.

### MODELS

Model Number	Switch Type
391-WT-4810-C1-80	SPDT Mercury
391-WT-7810-C1-80	SPDT Snap
391-WT-7810HM-C1-80	SPDT Hermetically Sealed Snap