

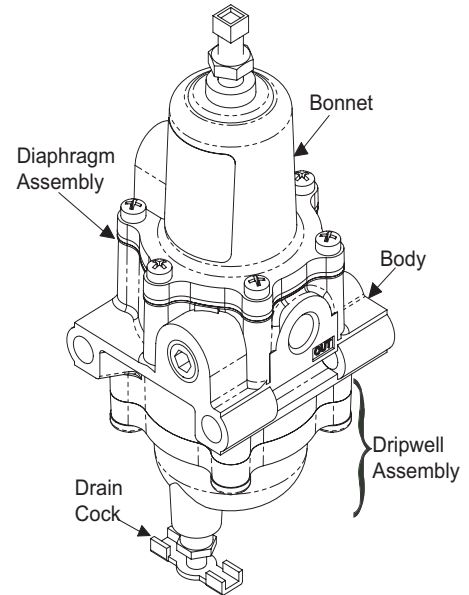

## Features

- The no-brass construction is well suited to harsh environments.
- Internal and external epoxy finish for superior corrosion resistance
- Non-bleed design to reduce consumption
- Integral Relief Valve
- A Gauge Port provides convenient pressure gauge mounting.
- The standard 5-micron filter minimizes internal contamination.
- The Filter Dripwell contains a Drain Plug to easily drain trapped liquids.
- Standard Tapped Exhaust
- Soft Relief Seat minimizes air loss
- Canadian Registration Number (CRN) certification for all territories and provinces.



## Operating Principles

When you turn the Adjustment Screw to a specific setpoint, the Spring exerts a downward force against the top of the Diaphragm Assembly. This downward force opens the Supply Valve. Output pressure flows through the Outlet Port and the passage to the Control Chamber where it creates an upward force on the bottom of the Diaphragm Assembly.

When the setpoint is reached, the force of the Spring that acts on the top of the Diaphragm Assembly balances with the force of output pressure that acts on the bottom of the Diaphragm Assembly and closes the Supply Valve.

When the output pressure increases above the setpoint, the Diaphragm Assembly moves upward to close the Supply Valve and open the Exhaust Valve. Output pressure flows through the Exhaust Valve and out of the Exhaust Vent on the side of the unit until it reaches the setpoint.

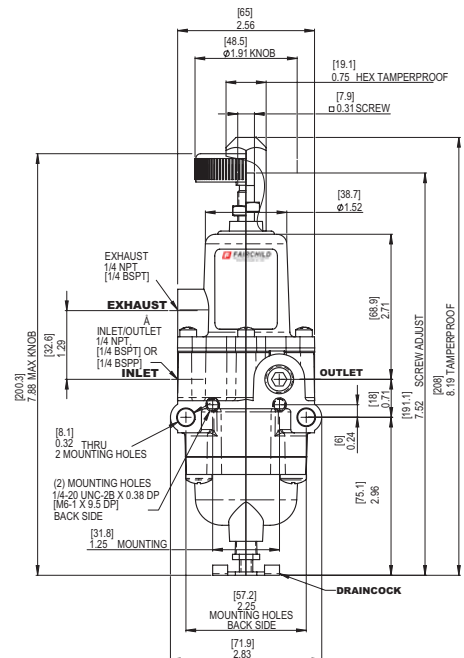

**Note:** Pipe plug is included

**Technical Information**

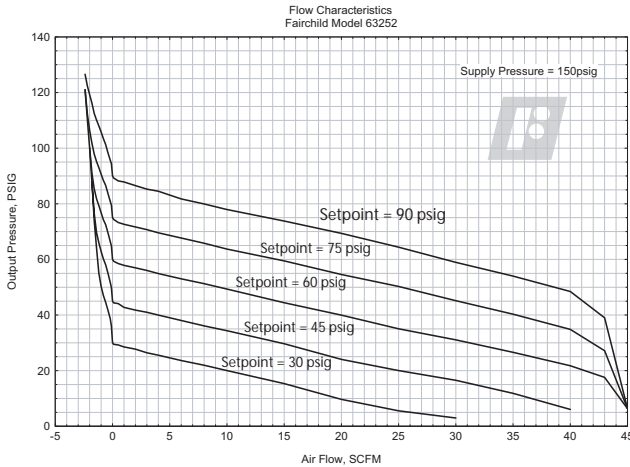

**Specifications**

**Supply Pressure**

250 psig, [17 BAR], (1700 kPa) Maximum

**Flow Capacity (SCFM)**

25 (42.5 m<sup>3</sup>/HR) @ 100 psig, [7 BAR], (700 kPa) supply and 20 psig, [1.5 BAR], (150 kPa) setpoint

**Exhaust Capacity (SCFM)**

0.8 (1.36 m<sup>3</sup>/HR) where downstream pressure is 5 psig, [.35 BAR], (35 kPa) above 20 psig, [1.5 BAR], (150 kPa) setpoint. (0.8 scfm for 120 # unit)

**Maximum Supply Pressure**

250 psig, [14 BAR], (1400 kPa)

**Consumption**

Undetectable

**Supply Pressure Effect**

Less than 1.25 psig, [.09 BAR], (9 kPa) change for 100 psig, [7.0 BAR], (700 kPa) change in supply pressure (1.90 psig for 120 # unit)

**Sensitivity**

1" (2.50 cm) Water Column

**Temperature Range**

-40° F to + 160° F, (-40° C to + 71° C)

**Materials of Construction**

Body and Housing . . . . .Epoxy Coated Aluminum

Trim . . . . .Stainless Steel, Nickel Plated Steel

Elastomers . . . . .Nitrile

**Catalog Information**

**Catalog Number** 6 3 2   2          

**Pressure Range**

psig	[BAR]	(kPa)
0.5-30	[0.03-2]	(3-200) . . . . . 3
1-60	[0.07-4]	(7-400) . . . . . 4
2-120	[0.14-8]	(14-800) . . . . . 5

**Port Size**

1/4" . . . . . 2

**Options**

NPT . . . . .	<span style="border: 1px solid black; padding: 2px;">N</span>
BSPP . . . . .	<span style="border: 1px solid black; padding: 2px;">H</span>
BSPT . . . . .	<span style="border: 1px solid black; padding: 2px;">U</span>
Knob . . . . .	<span style="border: 1px solid black; padding: 2px;">K</span>
Screw . . . . .	<span style="border: 1px solid black; padding: 2px;">S</span>
Tamper Proof . . . . .	<span style="border: 1px solid black; padding: 2px;">T</span>
Stainless Steel Trim . . . . .	<span style="border: 1px solid black; padding: 2px;">S</span>
Screen in Exhaust Port . . . . .	<span style="border: 1px solid black; padding: 2px;">M</span>
Quick Bleed Valve . . . . .	<span style="border: 1px solid black; padding: 2px;">C</span>
2" Gauge Option . . . . .	<span style="border: 1px solid black; padding: 2px;">G</span>

**Installation Instructions**

For installations instructions, refer to the *Fairchild Model 63 Pneumatic Filter Regulator Instruction, Operation and Maintenance Instructions, IS-10000063*.