

STANDARD PLATINUM RTD ASSEMBLIES - Pyromation standard RTD assemblies are constructed using either wire wound platinum elements or thin film elements with a reference resistance of 100 ohms at 0 °C, a temperature coefficient 0.003 85 °C⁻¹ and are in accordance with the following standards:

1. International Standard, IEC 60751:1995
2. American Standard, ASTM E1137-04

Other platinum elements and elements of other materials, resistances, and temperature coefficients are available as standard order items. See the 'Standard RTD Material Specification' chart located in this catalog section. Non-listed special sensor elements are also available by consulting with the factory.

RTD ELEMENT TERMINOLOGY

Temperature Coefficient of Resistance: The fractional change in element resistance per change of 1 °C, expressed as $\Omega/\Omega^{\circ}\text{C}$ or $\Omega \cdot \Omega^{-1} \cdot ^{\circ}\text{C}^{-1}$ or $^{\circ}\text{C}^{-1}$.

Accuracy: A statement of the initial element accuracy as measured at one point only, usually 0 °C [32 °F].

Interchangeability: An expression of the element material tolerance at various temperatures over the sensor range.

Typical 100 OHM Platinum Element Tolerances

TEMPERATURE		CLASS B (0.12%) ^[1] TOLERANCE ±[0.30 + 0.0050 t] °C		BAND 1 (0.1%) ^[1] TOLERANCE ±[0.26 + 0.0042 t] °C		CLASS A (0.06%) ^[1] TOLERANCE ±[0.15 + 0.0020 t] °C		BAND 3 (0.03%) ^[1] TOLERANCE ±[0.08 + 0.0017 t] °C		BAND 5 (0.01%) ^[2] TOLERANCE ±[0.03 + 0.0017 t] °C	
°C	[°F]	°C	[°F]	°C	[°F]	°C	[°F]	°C	[°F]	°C	[°F]
-200	[-328]	1.30	[2.34]	1.10	[1.98]	0.55	[0.99]	0.42	[0.76]	0.37	[0.67]
-100	[-148]	0.80	[1.44]	0.68	[1.22]	0.35	[0.63]	0.25	[0.45]	0.20	[0.36]
0	[32]	0.30	[0.54]	0.26	[0.47]	0.15	[0.27]	0.08	[0.14]	0.03	[0.05]
100	[212]	0.80	[1.44]	0.68	[1.22]	0.35	[0.63]	0.25	[0.45]	0.20	[0.36]
200	[392]	1.30	[2.34]	1.10	[1.98]	0.55	[0.99]	0.42	[0.76]	0.37	[0.67]
300	[572]	1.80	[3.24]	1.52	[2.74]	0.75	[1.35]	0.59	[1.06]	0.54	[0.97]
400	[752]	2.30	[4.14]	1.94	[3.49]	0.95	[1.71]	0.76	[1.37]	0.71	[1.28]
500	[932]	2.80	[5.04]	2.36	[4.25]	1.15	[2.07]	0.93	[1.67]	0.88	[1.58]
600	[1112]	3.30	[5.94]	2.78	[5.00]	1.35	[2.43]	1.10	[1.98]	1.05	[1.89]

where: |t| = value of temperature without regard to sign, °C

[1] The equations represent values for 3 and 4-wire PRTs. Caution must be exercised with 2-wire PRTs due to lead resistance.

[2] This tolerance can only be met with a 4-wire PRT.

Element Types: Single platinum elements of 100 ohms at 0 °C and duplex platinum elements of two 100 ohm sensors inside the same sheath are both available as standard. Consult factory for other duplex style of elements.

Sensor Leadwire: All standard RTD sensor leadwire is stranded, silver or nickel-plated copper with Teflon® or fiberglass insulation. Teflon® insulated leads are rated at 204 °C [400 °F] maximum and fiberglass insulated leads are rated at 482 °C [900 °F] maximum.

Element Connections: RTD sensor assemblies are available with 2, 3, and 4 wire leads. Two wire connected elements do not provide lead resistance compensation for the measuring device. Three and four wire connected elements provide a means for compensating for lead resistance between the sensor and the measuring device.

Temperature Limits:

Low range (L) RTD assemblies are constructed using Teflon® materials and low temperature epoxies to make them resistant to moisture penetration. These units are rated at 204 °C [400 °F] maximum.

High range (H) RTD assemblies are constructed using nickel element leads, MgO insulation, and other materials suitable for maximum temperatures of up to 600 °C [1112 °F].

Self-Heating: Self-heating is the rise in the measured temperature caused by the power dissipated in the element. Self-heating error is affected by the thermal conductivity and velocity of the process being measured and is negligible for most applications. The self-heating effect at 25 °C [77 °F] in water flowing at 1 m/s [3 ft/s] on a 3/16" OD stainless steel sheath diameter RTD is 50 mW/ °C typical.

Thermal Response: The time required to sense 63.2% of a step temperature change from (20 to 77) °C [68 to 171] °F in water flowing at 1 m/s [3 ft/s].

Two-Wire: Provides one connection to each end of the element. This construction is suitable where the resistance of the lead wire may be considered as an additive constant in the circuit, and particularly where the changes in lead resistance due to ambient temperature changes may be ignored.

Three-Wire: Provides one connection to one end of the element and two to the other end of the element. Connected to an instrument designed to accept three wire input, sufficient compensation is usually achieved for leadwire resistance and temperature change in leadwire resistance. This is the most commonly used configuration.

Four-Wire: Provides two connections to each end of the element to completely compensate for leadwire resistance and temperature change in leadwire. This configuration is used where highly accurate temperature measurement is vital.

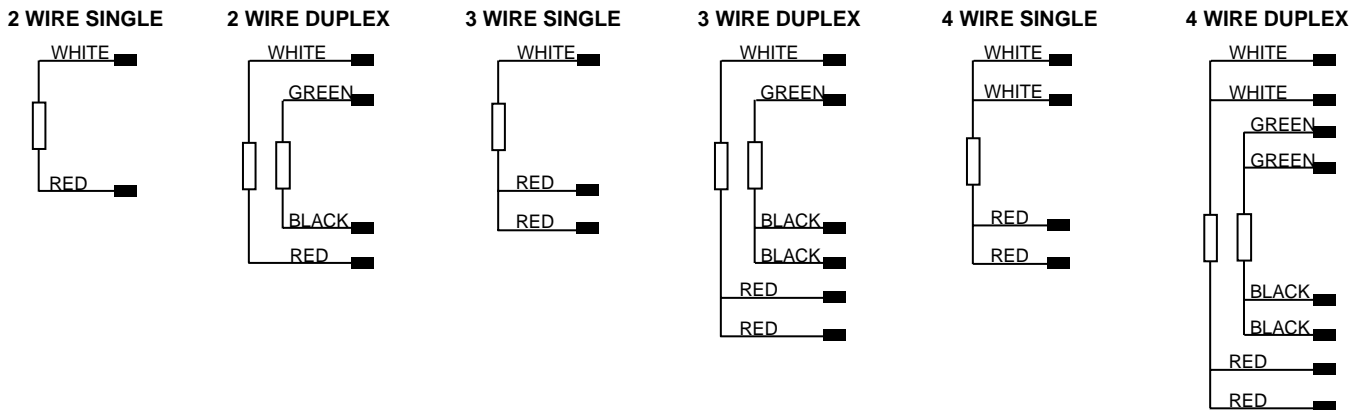

Pyromation Standard RTD Element Specifications

ELEMENT MATERIAL ^[1]	ELEMENT TYPE	RESISTANCE @ 0 °C	TEMPERATURE COEFFICIENT	OPERATING RANGE ^[2]	AVAILABLE TOLERANCES @ 0 °C						
					±0.5%	±0.2%	±0.12%	±0.1%	±0.6%	±0.03%	±0.05%
Platinum	Thin Film	100 Ohm	$\alpha=0.00385\text{ }^{\circ}\text{C}^{-1}$	(-70 to 550) °C [-94 to 1022] °F			X		X		
Platinum	Wire Wound	100 Ohm	$\alpha=0.00385\text{ }^{\circ}\text{C}^{-1}$	(-200 to 600) °C [-328 to 1112] °F				X		X	X
Platinum	Wire Wound	100 Ohm	$\alpha=0.00392\text{ }^{\circ}\text{C}^{-1}$	(-200 to 600) °C [-328 to 1112] °F				X		X	
Platinum	Wire Wound	200 Ohm	$\alpha=0.00385\text{ }^{\circ}\text{C}^{-1}$	(-200 to 600) °C [-328 to 1112] °F				X		X	X
Platinum	Wire Wound	200 Ohm	$\alpha=0.00392\text{ }^{\circ}\text{C}^{-1}$	(-200 to 600) °C [-328 to 1112] °F				X		X	
Platinum	Thin Film	500 Ohm	$\alpha=0.00385\text{ }^{\circ}\text{C}^{-1}$	(-70 to 550) °C [-94 to 1022] °F			X				
Platinum	Thin Film	1000 Ohm	$\alpha=0.00385\text{ }^{\circ}\text{C}^{-1}$	(-70 to 550) °C [-94 to 1022] °F			X				
Copper ^[3]	Wire Wound	10 Ohm	$\alpha=0.00427\text{ }^{\circ}\text{C}^{-1}$	(-101 to 204) °C [-150 to 400] °F		X					
Nickel	Wire Wound	120 Ohm	$\alpha=0.00672\text{ }^{\circ}\text{C}^{-1}$	(-101 to 204) °C [-150 to 400] °F	X						
Nickel-Iron	Wire Wound	604 Ohm	$\alpha=0.00518\text{ }^{\circ}\text{C}^{-1}$	(-101 to 204) °C [-150 to 400] °F	X						

[1]: Sensing elements of other materials, base values, and temperature coefficients are available upon request.

[2]: Stated operating ranges are typical values and are dependant upon the sensing element, element substrate, and the construction style of the total sensor assembly. Sensor assemblies to exceed the stated limits may be available upon request.

[3]: Base resistance of 10 Ohm Copper RTD is measured at 25 °C.