

Process Gauges

SOLFRUNT® 4-1/2" Test Gauges

DESCRIPTION

Series 1400 4-1/2" SOLFRUNT test gauges are designed to combine laboratory test gauge accuracy with carrying case or rolling test stand portability, and frequently are permanently installed on instrument shop test benches or test panels. These gauges feature a solid front case, which provides a partition between the pressure measuring element and the window with a pressure relieving back. Accurate gauge reading is accomplished by sighting the knife edge of the indicating pointer with the paralleling pressure graduation, while simultaneously eliminating the pointer's image on the mirrored dial edge. An adjustable pointer provides front zero adjustment. Other calibration adjustments can be made from the back without removal from the case. Metric ranges are available upon request.



SPECIFICATIONS

- DIAL SIZE: 4-1/2"
- CASE: SOLFRUNT, Cast aluminum, black finish with aluminum pressure relieving back
 - 1403: Front flanged for panel mounting
 - 1404: Flangeless for stem mounting
- RING: 1403: Steel hinged, black finish; 1404: Aluminum snap-lock bayonet, black
- WINDOW: Molded acrylic with gasket
- POINTER: Knife-edged, black, adjustable
- DIAL: White coated aluminum with black markings and mirrored edge
- MOVEMENT: Geared ARC-LOC® with parts of phosphor bronze and stainless steel to minimize friction and wear
- BOURDON TUBE: Silver brazed
 - Phosphor bronze: 30" Hg VAC through 60 psi
 - Beryllium copper: 100 through 5000 psi
- CONNECTION: 1/2-14 ANPT standard (1/4-18 ANPT optional), brass
- ACCURACY: ±0.25% of span (Grade 3A)

STANDARD RANGES

MAXIMUM INDICATION	FIGURE INTERVALS	SMALLEST INTERVALS
15	1	0.05
30	2	0.1
60	5	0.2
100	5	0.5
160	10	1
200	10	1
300	20	1
400	20	2
600	50	2
1000	50	5
1500	100	5
2000	100	10
3000	200	10
5000	200	20
30" Hg VAC	2" Hg VAC	0.1" Hg VAC

Pressure ranges in psi unless otherwise indicated

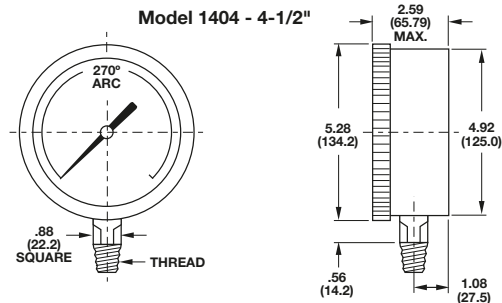
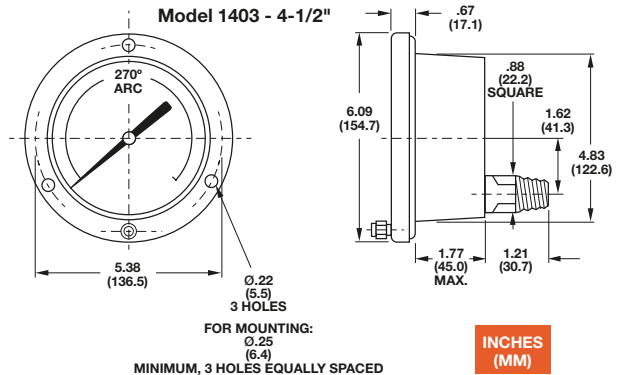

© 2002, by AMETEK, Inc. All rights reserved. 15M1102A (160126) Specifications are subject to change without notice. Visit our Web sites for the most up-to-date information.



For Gauges/Thermometers:
U.S. GAUGE
820 Pennsylvania Blvd.
Feasterville, PA 19053 U.S.A.
Tel: (215) 355-6900
Fax: (215) 354-1802
www.ametekusg.com
Customer Service Tel: (863) 534-1504
Customer Service Fax: (863) 533-7465

For Electronic Products:
PMT PRODUCTS
820 Pennsylvania Blvd.
Feasterville, PA 19053 U.S.A.
Tel: (215) 355-6900
Fax: (215) 354-1800
www.ametekusg.com

For Diaphragm Seals:
M&G PRODUCTS
8600 Somerset Drive
Largo, FL 33773 U.S.A.
Tel: (727) 536-7831
Fax: (727) 539-6882
www.ametek.com/tci





Process Gauges

SOLFRUNT® 6" Test Gauges

DESCRIPTION

Series 1400 6" SOLFRUNT test gauges are used in instrument shops, laboratories and other critical applications, where a high degree of accuracy is required and operator error must be minimized. Panel or stem mounted, these gauges offer the same accuracy, case, dial, and calibration features as the 4-1/2" series, except with better readability because of increased length of graduated arc. Metric ranges are available upon request.

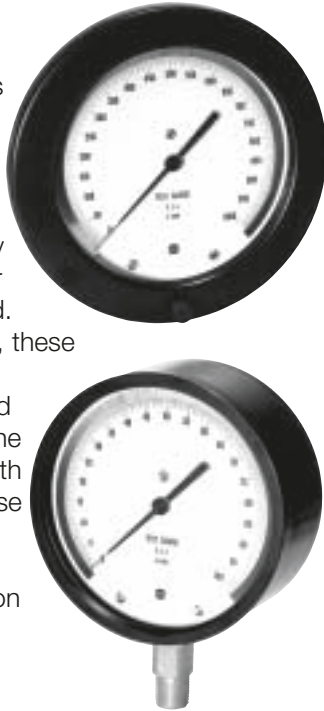

SPECIFICATIONS

- DIAL SIZE: 6"
- CASE: SOLFRUNT, cast aluminum, black finish with BUNA-N® pressure relieving back
 - 1403: Front flanged for panel mounting
 - 1404: Flangeless for stem mounting
- RING: 1403: Steel hinged, black finish; 1404: Aluminum, threaded, black finish
- WINDOW: Molded acrylic with gasket
- POINTER: Knife-edged, black, adjustable
- DIAL: White coated aluminum with black markings and mirrored edge
- MOVEMENT: Geared ARC-LOC® with parts of phosphor bronze and stainless steel to minimize friction and wear
- BOURDON TUBE: Silver brazed
 - Phosphor bronze: 30" Hg VAC through 60 psi
 - Beryllium copper: 100 through 5000 psi
- CONNECTION: 1/2-14 ANPT standard (1/4-18 ANPT optional), brass
- ACCURACY: ±0.25% of span (Grade 3A)

STANDARD RANGES

MAXIMUM INDICATION	FIGURE INTERVALS	SMALLEST INTERVALS
15	1	0.05
30	2	0.1
60	5	0.2
100	5	0.5
160	10	1
200	10	1
300	20	1
600	50	2
1000	50	5
1500	100	5
2000	100	10
3000	200	10
5000	200	20
30" Hg VAC	2" Hg VAC	0.1" Hg VAC

Pressure ranges in psi unless otherwise indicated

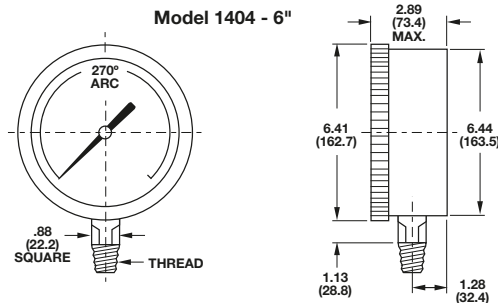
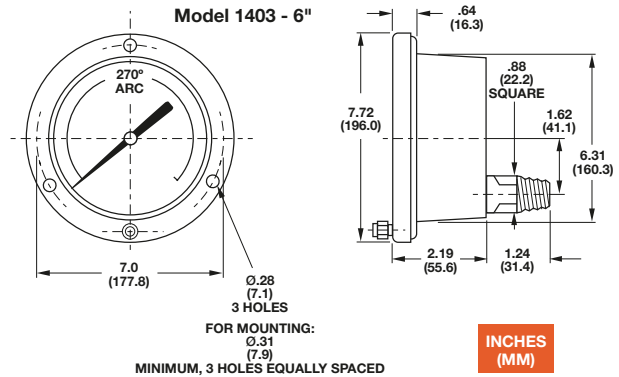

© 2002, by AMETEK, Inc. All rights reserved. 15M1102A (160126) Specifications are subject to change without notice. Visit our Web sites for the most up-to-date information.



For Gauges/Thermometers:
U.S. GAUGE
 820 Pennsylvania Blvd.
 Feasterville, PA 19053 U.S.A.
 Tel: (215) 355-6900
 Fax: (215) 354-1802
 www.ametekusg.com

Customer Service Tel: (863) 534-1504
 Customer Service Fax: (863) 533-7465

For Electronic Products:
PMT PRODUCTS
 820 Pennsylvania Blvd.
 Feasterville, PA 19053 U.S.A.
 Tel: (215) 355-6900
 Fax: (215) 354-1800
 www.ametekusg.com

For Diaphragm Seals:
M&G PRODUCTS
 8600 Somerset Drive
 Largo, FL 33773 U.S.A.
 Tel: (727) 536-7831
 Fax: (727) 539-6882
 www.ametek.com/tci





Process Gauges

SOLFRUNT® Test Gauges

SPEC NUMBER SELECTION CHART

Test Gauges	Model No. 1404 1/2-14 ANPT, Low Mount		Model No. 1403 1/2-14 ANPT, Lower-Back Mount	
	Phosphor Bronze (30" Hg VAC through 60 psi) Beryllium Copper (100 psi through 5,000 psi)	Phosphor Bronze (30" Hg VAC through 60 psi) Beryllium Copper (100 psi through 5,000 psi)	Phosphor Bronze (30" Hg VAC through 60 psi) Beryllium Copper (100 psi through 5,000 psi)	Phosphor Bronze (30" Hg VAC through 60 psi) Beryllium Copper (100 psi through 5,000 psi)
Bourdon Tube	Brass	Brass	Brass	Brass
Connection	4-1/2"	6"	4-1/2"	6"
Size	Spec No.	Spec No.	Spec No.	Spec No.
Range				
0 - 30" Hg	132243	132577	132258	132592
0 - 15 psi	132240	132578	132255	132593
0 - 30 psi	132241	132579	132256	132594
0 - 60 psi	132242	132580	132257	132595
0 - 100 psi	132244	132581	132259	132596
0 - 160 psi	132245	132582	132260	132597
0 - 200 psi	132246	132583	132261	132598
0 - 300 psi	132247	132584	132262	132599
0 - 400 psi	132248	-	-	-
0 - 600 psi	132249	132586	132264	132601
0 - 1000 psi	132250	132587	132265	132602
0 - 1500 psi	132251	-	-	132603
0 - 2000 psi	132252	132589	132267	132604
0 - 3000 psi	132253	132590	132268	132605
0 - 5000 psi	132254	132591	132269	132606

* 1/4-18 ANPT available - use 133XXX when ordering

© 2002, by AMETEK, Inc. All rights reserved. 15M1102A (160126) Specifications are subject to change without notice. Visit our Web sites for the most up-to-date information.



For Gauges/Thermometers:
U.S. GAUGE
 820 Pennsylvania Blvd.
 Feasterville, PA 19053 U.S.A.
 Tel: (215) 355-6900
 Fax: (215) 354-1802
 www.ametekusg.com

Customer Service Tel: (863) 534-1504
 Customer Service Fax: (863) 533-7465

For Electronic Products:
PMT PRODUCTS
 820 Pennsylvania Blvd.
 Feasterville, PA 19053 U.S.A.
 Tel: (215) 355-6900
 Fax: (215) 354-1800
 www.ametekusg.com

For Diaphragm Seals:
M&G PRODUCTS
 8600 Somerset Drive
 Largo, FL 33773 U.S.A.
 Tel: (727) 536-7831
 Fax: (727) 539-6882
 www.ametek.com/tci

