

Series
BPI

Battery Powered Temperature Indicator

RTD or T/C Input, 4-Digit Display, Selectable °F or °C

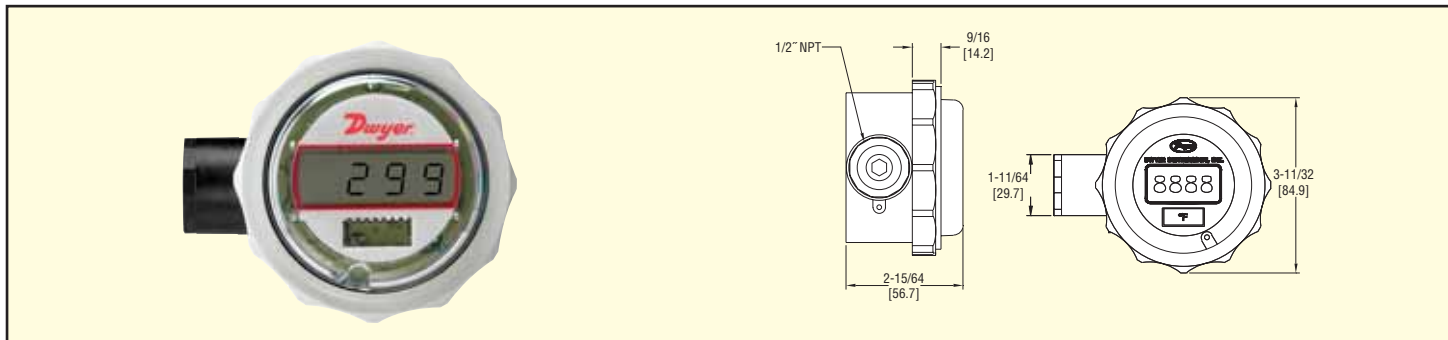

The Series BPI Battery Powered Indicator accepts RTD or Thermocouple input and provides local or remote display of temperature measurements. Quickly navigate the menu system to customize for each application. Three push buttons allow the user to select input type, engineering units (°F or °C), offset temperature, decimal point position, and password protection. The indicator is housed in a polycarbonate NEMA 4X (IP65) enclosure for additional protection from the environment.

Model No.	Input
BPI - 101	3-wire Pt100 or Ni120
BPI - 102	K, J, T, N, R, S, E, or F thermocouples

Measuring Ranges

Sensor	Range °F (°C)	Sensor	Range °F (°C)
K	-328 to 2498°F (-200 to 1370°C)	S	14 to 3200°F (-10 to 1760°C)
J	-148 to 2192°F (-100 to 1200°C)	E	-328 to 1832°F (-200 to 1000°C)
T	-346 to 752°F (-210 to 400°C)	F	-148 to 1112°F (-100 to 600°C)
N	-292 to 2372°F (-180 to 1300°C)	Pt100Ω	-148 to 1472°F (-100 to 800°C)
R	14 to 3200°F (-10 to 1760°C)	Ni120	-148 to 1472°F (-100 to 800°C)

SPECIFICATIONS

Inputs: Thermocouple or RTD depending on model.

Accuracy: Thermocouple Input: ±0.1% of FS, ±0.5°C (plus sensor); RTD: ±0.2°C ±0.1% of reading (plus sensor error).

Power Requirements: 3.6 V Lithium battery.

Battery Life: >2 years.

Display: 4-digit LCD.

Resolution: 0.1°C.

Ambient Operating Temperature: 14 to 158°F (-10 to 70°C).

Storage Temperature: -4 to 185°F (-20 to 85°C).

Weight: 6.0 oz (170 g).

Front Panel Protection: NEMA 4X (IP65).

Agency Approvals: CE.