

BATCH CONTROLLER

WITH TWO STAGE CONTROL / PULSE AND ANALOG OUTPUT IN RELATION TO THE FLOW RATE



Features

- Large display shows preset value, running batch value and instantaneous flow rate.
- Self-learning overrun correction.
- Easy operation to enter a batch value and to control the process.
- Count-up and count-down function available.
- Selectable on-screen engineering units; volumetric or mass.
- Ability to process all types of flowmeter signals.
- Operational temperature -30°C up to +80°C (-22°F up to 178°F).
- Very compact design for panel mount, wall mount or field mount applications.
- Rugged aluminum field mount enclosure IP67/NEMA4X.
- Intrinsically Safe
⊕ II 1 GD EEx ia IIB/IIC T4 T100°C.
- Explosion/flame proof ⊕ II 2 GD EEx d IIB T5.
- Full Modbus communication RS232/485/TTL.
- Loop or battery powered, 8 - 24V AC/DC or 115 - 230V AC power supply.
- Sensor supply 3.2 - 8.2 - 12 - 24V DC.

Signal output

- Two configurable control outputs: for two-stage or one-stage control.
- (0)4 - 20mA / 0 - 10V DC according to flow rate.
- Scaled pulse output according to acc. total.

Signal input

Flow

- Reed-switch.
- NAMUR.
- NPN/PNP pulse.
- Sine wave (coil).
- Active pulse signals.
- (0)4 - 20mA.
- 0 - 10V DC.

Status

- Remote control: start.
- Remote control: pause / stop.

Applications

- For batching small up to very large quantities. Flow rate indication and / or retransmission is required. Alternative basic model: F030 and F130 or more sophisticated models: F136 and 300 series.

General information

Introduction

The F131 offers in addition to the standard functions an analog output signal in relation to the flow rate. The operator can enter a batch quantity easily or execute repeating batches. During the batch, the preset value is displayed as well as the batched (or remaining) quantity and the flow rate. The automatic self-learning overrun correction will ensure an accurate result each batch again. A wide selection of options further enhance this model's capabilities.

Display

The display has large 17mm (0.67") and 8mm (0.31") digits. Besides the process information, a seven digit resettable "day total" is available as well as an eleven digit non-resettable accumulated total. All are backed-up in EEPROM memory every minute.

Configuration

All configuration settings are accessed via a simple operator menu which can be pass-code protected. Each setting is clearly indicated with an alphanumeric description, therefore avoiding confusing abbreviations and baffling codes. All settings are safely stored in EEPROM memory in the event of sudden power failure.

Analog output signal

The flow rate is re-transmitted with the (0)4 - 20mA or 0 - 10V DC output signal. The output signal is updated ten times per second with a filter function being available to smoothen out the signal if desired. The output value is user defined in relation to the flow rate, e.g. 4mA equals to 15L/Hr and 20mA equals to 2000L/Hr. The output signal can be passive, active or isolated where the passive output type will loop power the F131 as well.

Control outputs

Two outputs are available which can be configured to operate as two stage control for large batch quantities or one stage control for smaller batches, where the second output is available as a scaled pulse output. The maximum output frequency is 64Hz. The output signals can be a passive NPN, active PNP or an isolated electro-mechanical relay.

Signal input

The F131 will accept most pulse and analog input signals for flow or mass flow measurement. The input signal type can be selected by the user in the configuration menu without having to adjust any sensitive mechanical dip-switches or jumpers.

Communication

All process data and settings can be read and modified manually or through the Modbus communication link (RS232 / RS485). If desired, the batch process can even be started and stopped through communication. Full Modbus functionality remains available for the Intrinsically Safe version (TTL).

Hazardous areas

For hazardous area applications, this model has been ATEX certified Intrinsically Safe $\text{Ex II 1 GD EEx ia IIB / IIC T4 T100}^{\circ}\text{C}$ with an allowed operational temperature of -30°C to $+70^{\circ}\text{C}$ (-22°F to $+158^{\circ}\text{F}$). A flame proof enclosure is also available with the rating $\text{Ex II 2 GD EEx d IIB T5}$.

Enclosures

Various types of enclosures can be selected, all ATEX approved. As standard the F131 is supplied in an GRP panel mount enclosure, which can be converted to an GRP field mount enclosure. Most popular is our rugged aluminum field mount enclosure with IP67 / NEMA 4X rating. Both European or U.S. cable gland entry threads are available.

Overview application F131

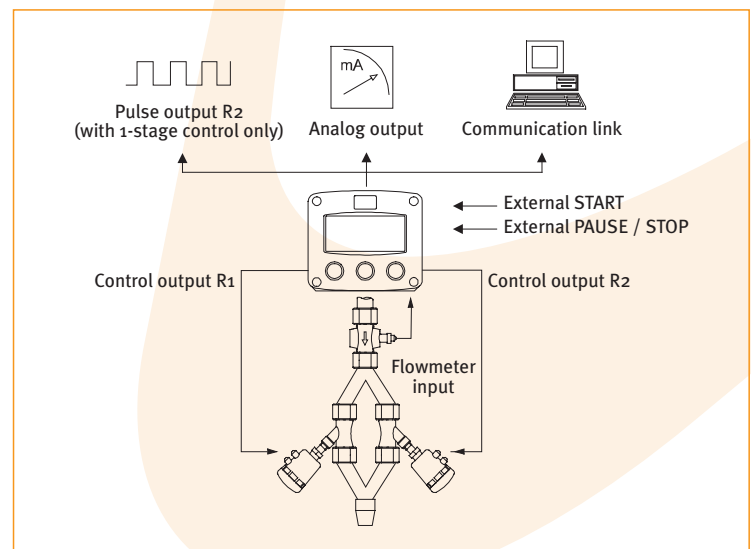

Dimensions enclosures Aluminum & GRP panel mount enclosure

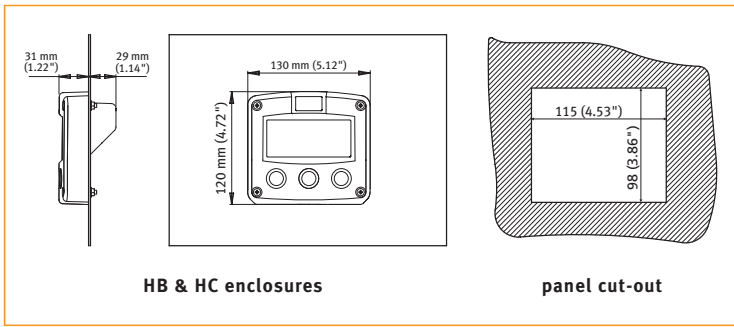

HB & HC enclosures

panel cut-out

Aluminum & GRP field / wall mount enclosures

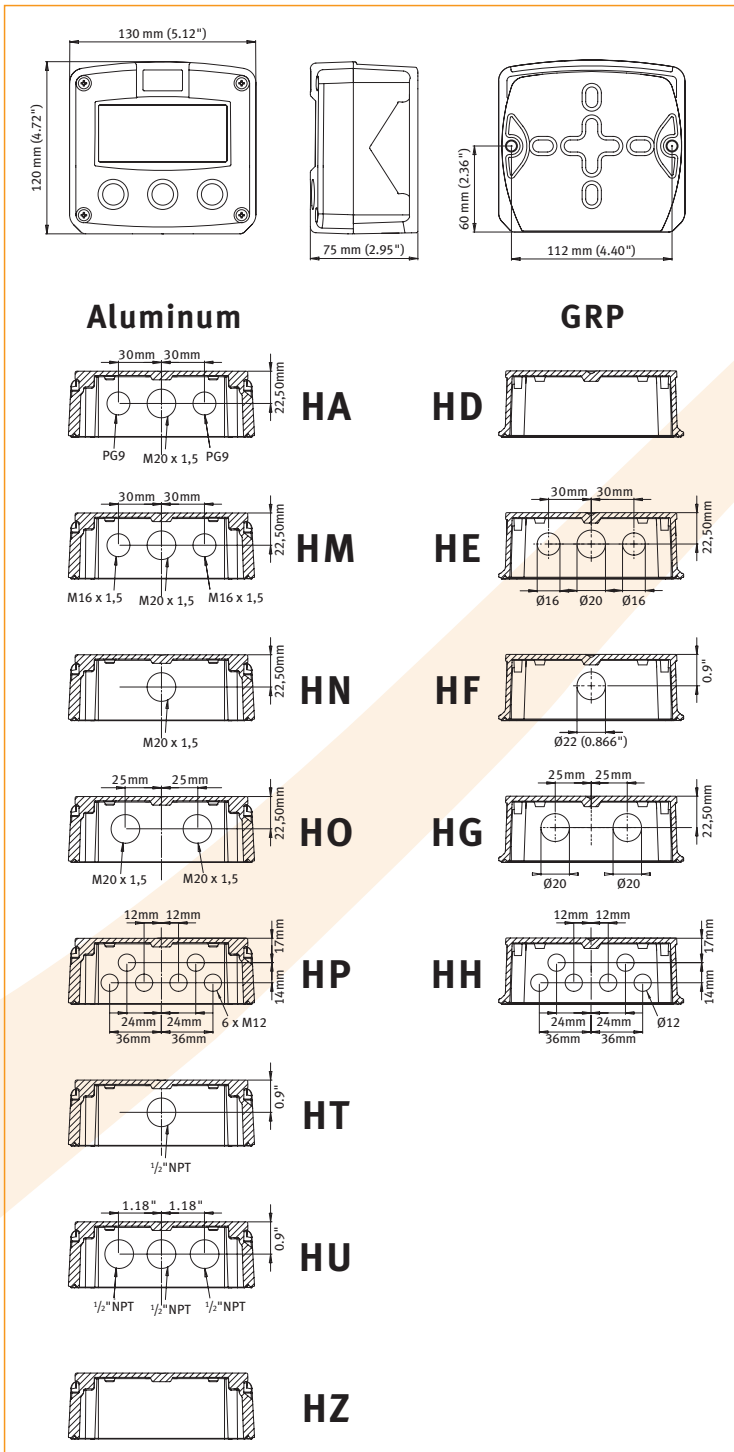

Aluminum

GRP

HA

HD

HM

HE

HN

HF

HO

HG

HP

HH

HT

HU

HZ

Terminal connections

	COMMUNICATION / BACKLIGHT	26	27	28	29	30	31	
	CB: RS232	⊥	DTR +12V	RXD	TXD			
	CH: RS485 - 2 wire	⊥		A	B			
	CI: RS485 - 4 wire	⊥		A	B	Y	Z	
	CT: TTL Intrinsically Safe	⊥				RXD	TXD	
		⊥	DTR +12V					
	ZB: Backlight option	⊥	+	+	+	+	+	
								(With PD / PF / PM terminals 26 / 31 are not available, Backlight power supply is integrated.)

	STOP INPUT	15	16	
		⊥	+	+
	START INPUT	12	13	14
		⊥	+	+
	FLOWMETER INPUT	9	10	11
	P: coil	⊥	~	~
	P: reed switch / NPN	⊥	+	+
	P: PNP	⊥	-	-
	P: namur	⊥	-	-
	P: active signal	⊥	+	+
	A: (0/4 - 20mA)	⊥	+	+
	U: 0 - 10V	⊥	+	+
	A - PL: 4 - 20mA	⊥	+	+

	ANALOG OUTPUT	7	8
	AA: 4 - 20mA	⊥	+
	AB: 0 - 20mA	⊥	+
	AF: 4 - 20mA	⊥	+
	AI: 4 - 20mA	⊥	+
	AP: 4 - 20mA	⊥	+
	AU: 0 - 10V	⊥	+

	CONTROL / PULSE OUTPUT R1	5	6
	OA: active 24V DC	⊥	+
	OT: passive trans.	⊥	+
	OR: mech. relay	~	~

	CONTROL / PULSE OUTPUT R2	3	4
	OA: active 24V DC	⊥	+
	OT: passive trans.	⊥	+
	OR: mech. relay	~	~

	POWER SUPPLY OPTIONAL	1	2
	PD: 8 - 24V AC	⊥	~
	PD: 8 - 24V DC	-	+
	PD: Xi: 16 - 30V DC	-	+
	PF: 24V AC	⊥	~
	PF: 24V DC	-	+
	PM: 115 - 230V AC	⊥	~

PX: 8 - 30V DC
Output loop powered unit with type AP (terminals GND - 1 - 2 are not available)

PB / PC: battery powered internal long life Lithium battery (terminals GND - 1 - 2 are not available)

PL: input loop powered (terminals GND - 1 - 2 are not available)

Typical wiring diagram F131-P-(AP)-CH-OT-PB

Typical wiring diagram F131-P-AP-CH-OT-PX

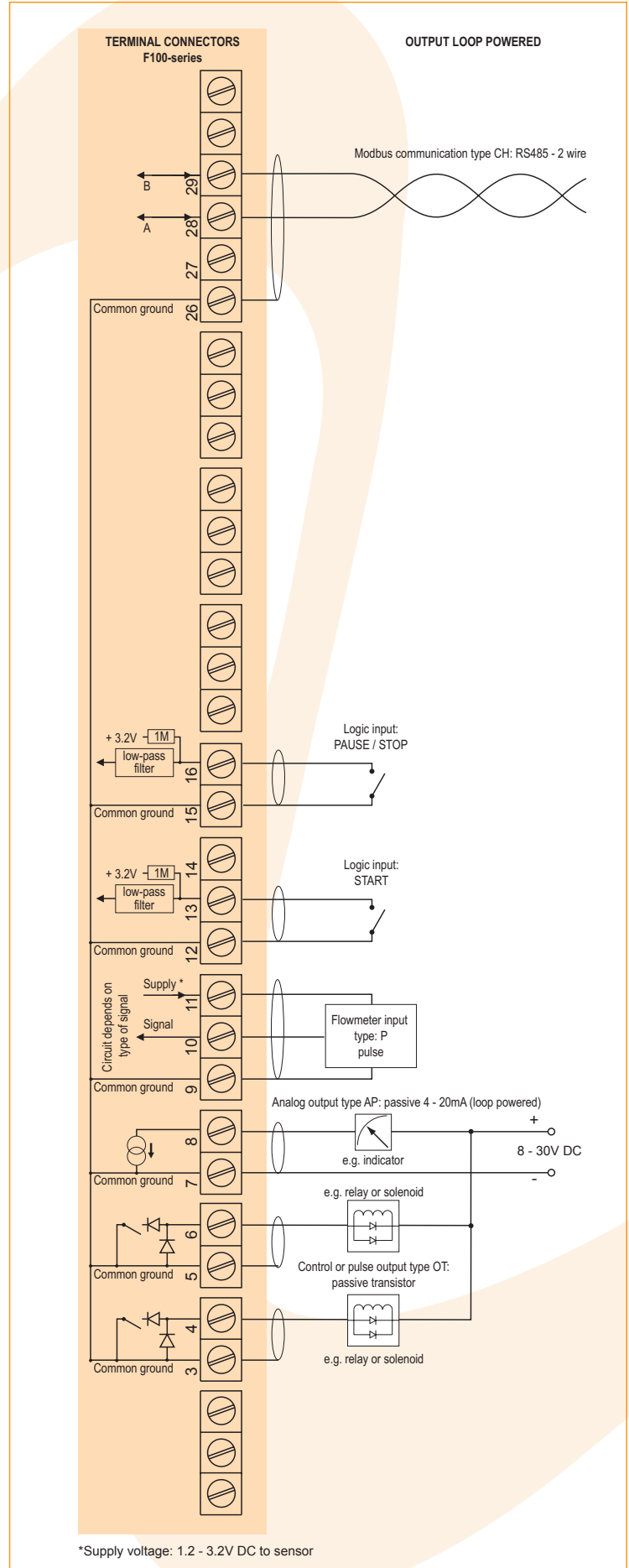
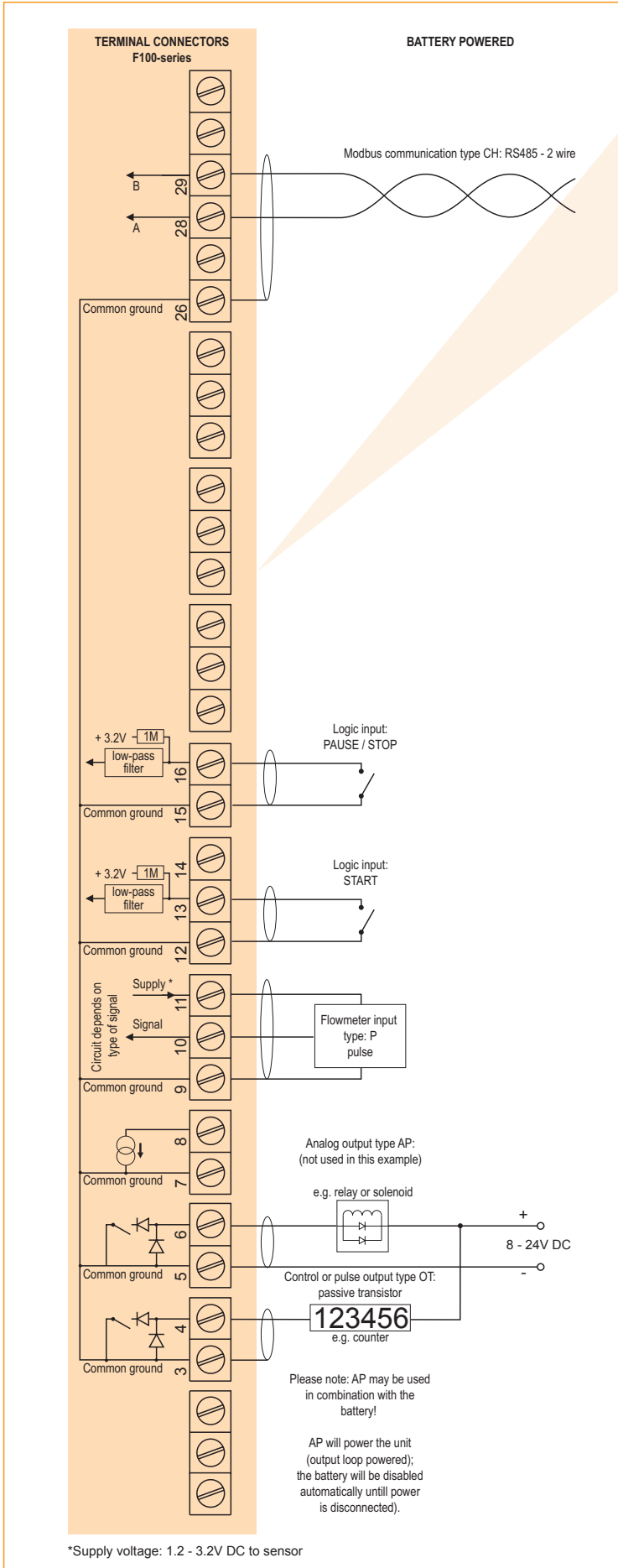

Typical wiring diagram F131-A-AA-CB-OA-PD

Typical wiring diagram F131-A-AI-CI-OR-PM

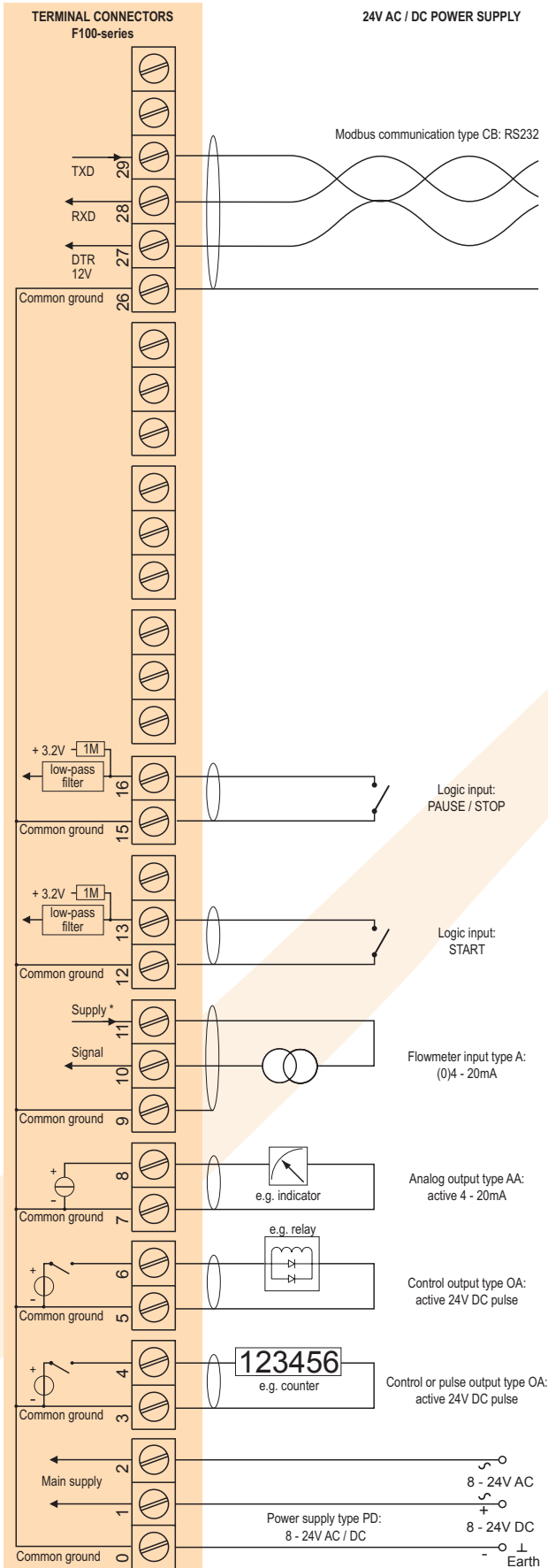

*Supply voltage: 3.2 - 8.2 - 12 - 24V DC to sensor

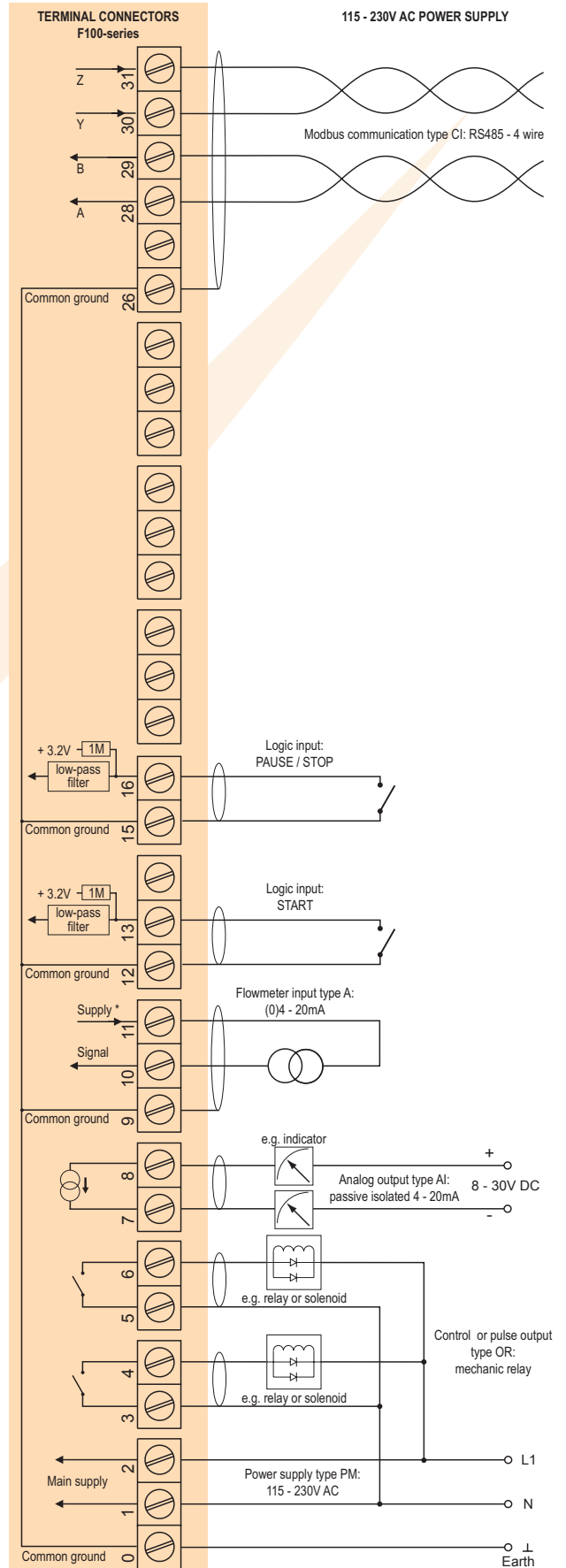

*Supply voltage: 3.2 - 8.2 - 12 - 24V DC to sensor

Hazardous area applications

The F131-XI has been ATEX approved by KEMA for use in Intrinsically Safe applications. It is approved according to Ex II 1 GD EEx ia IIB/IIC T4 T100°C for gas and dust applications with an operational temperature range of -30°C to +70°C (-22°F to +158°F). Besides the I.S. power supplies for the control outputs, it is allowed to connect up to three I.S. power supplies in IIB applications or one in IIC applications. Full functionality of the F131 remains available, including two stage control, 4 - 20mA output, pulse output and Modbus communication (type CT). Power supply type PD-XI offers a 8.2V sensor supply e.g. for one Namur sensor. A flame proof enclosure with rating Ex II 2 GD EEx d IIB T5 is available as well. Please contact your supplier for further details.

Certificate of conformity KEMA 03ATEX1074 X



Configuration example IIB and IIC

F131-P-(AP)-(CT)-OT-PC-(PX)-XI - Battery powered unit

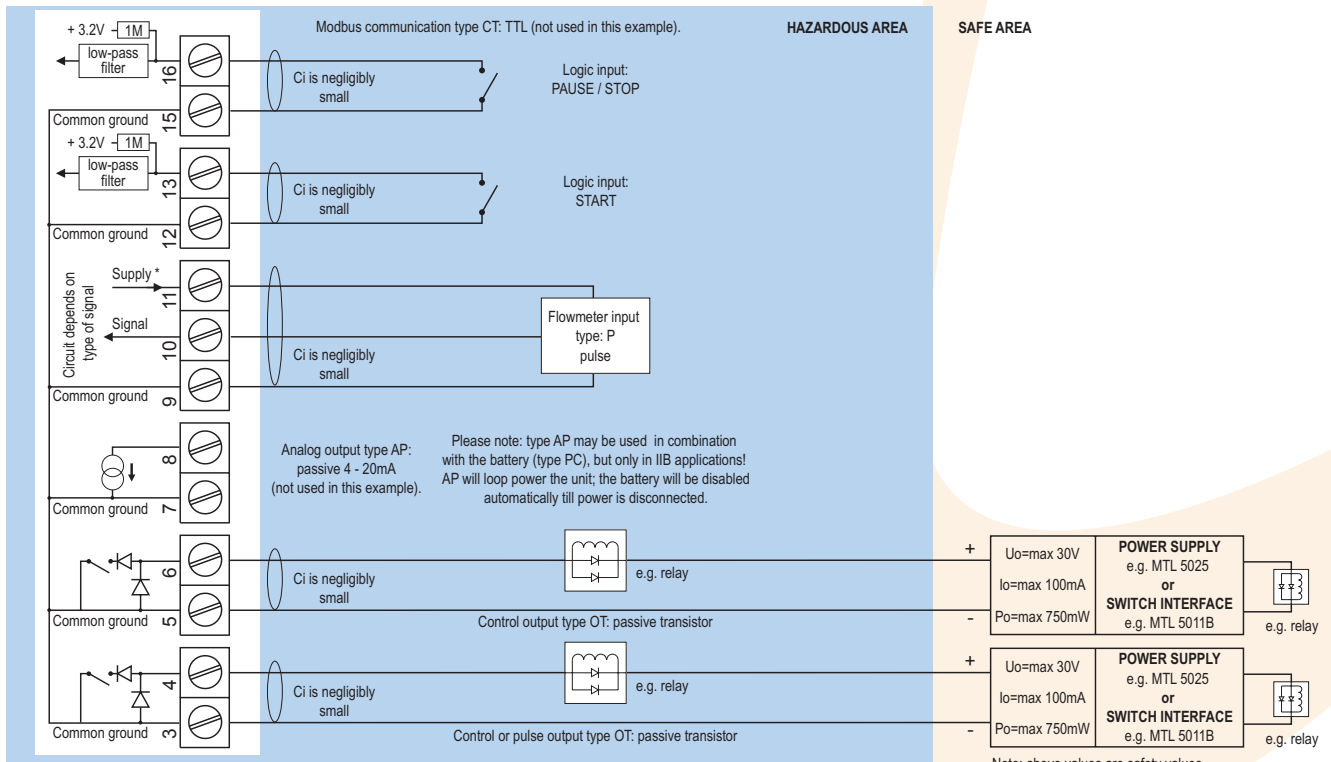

Configuration example IIB and IIC - F131-P-AP-(CT)-OT-PX-XI - Output loop powered

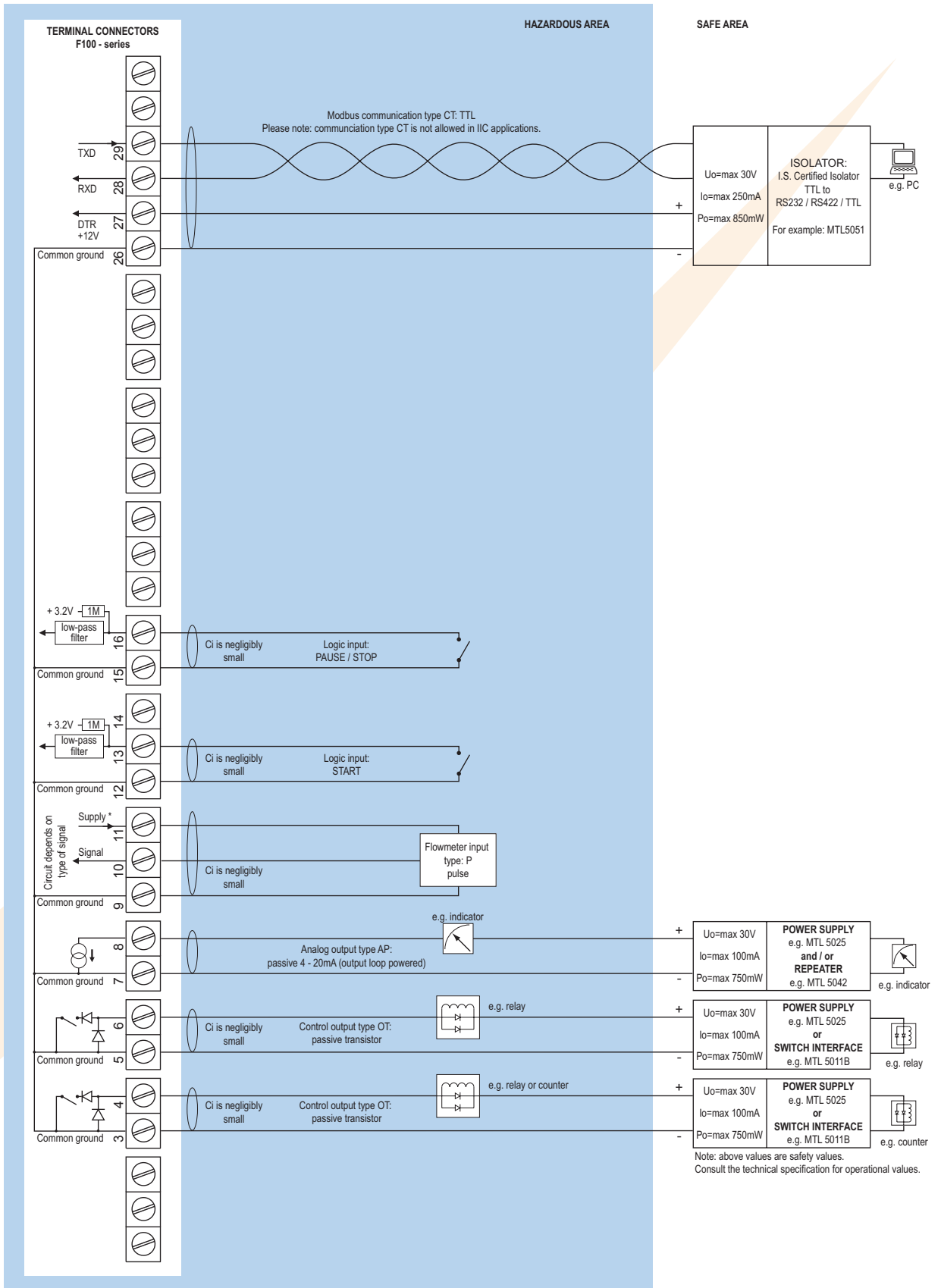

* Note sensor supply voltage: 1.2V DC for coil sensors or 3.2V DC for other pulse sensors.

Configuration example IIB and IIC - F131-A-AF-(CT)-OT-PD-XI - Power supply 16 - 30V DC

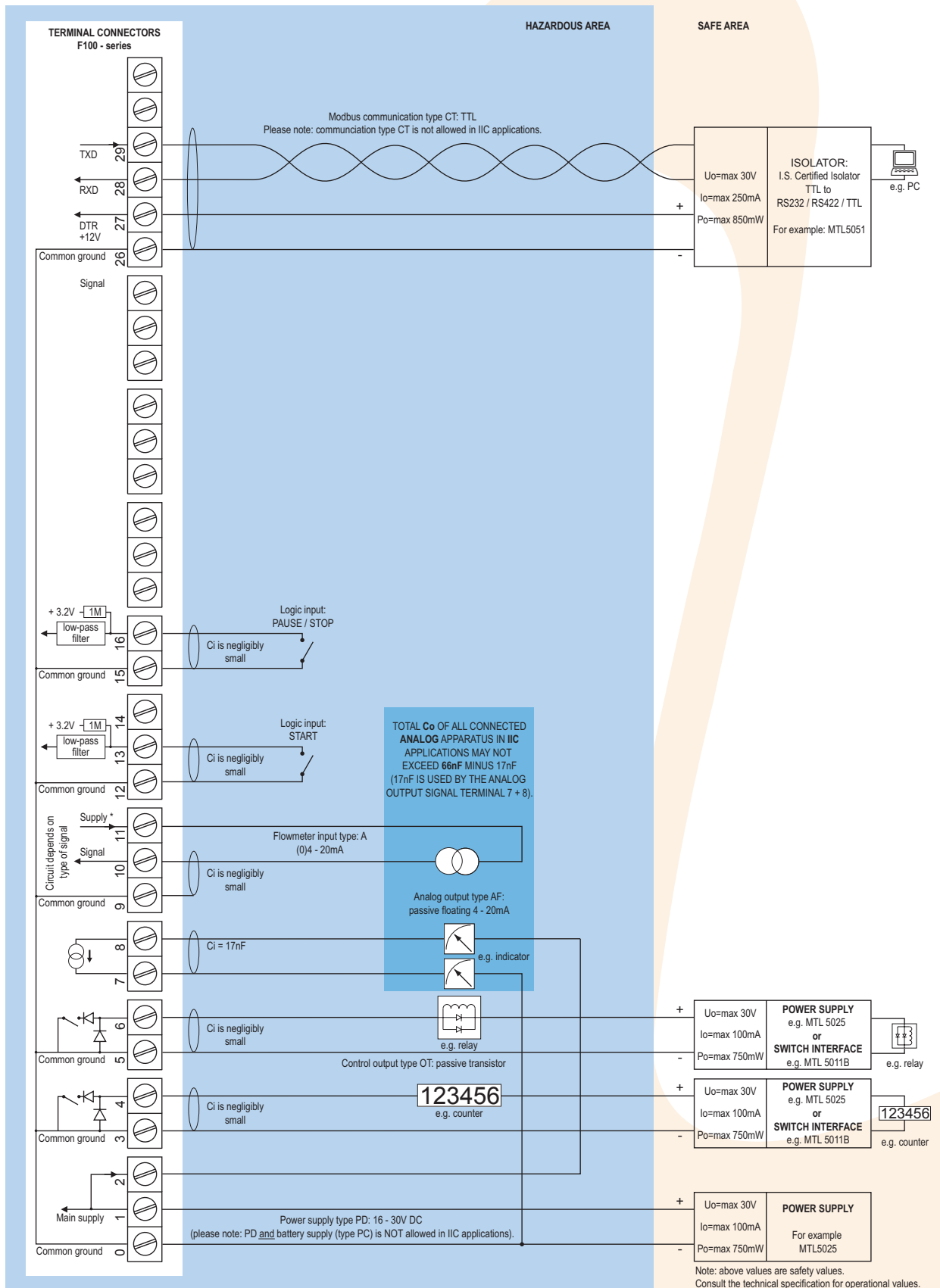

* Note power supply type PD: the supply voltage to pulse sensors is maximum 8.7V (U_o=max 8.7V I_o=max 25mA P_o=max 150mW) and to analog sensors as connected to terminal 1 (internally linked).

Configuration example IIB - F131-A-AF-CT-OT-(PC)-(PD)-(PL)-XI - Power supply 16 - 30V DC, battery or loop powered

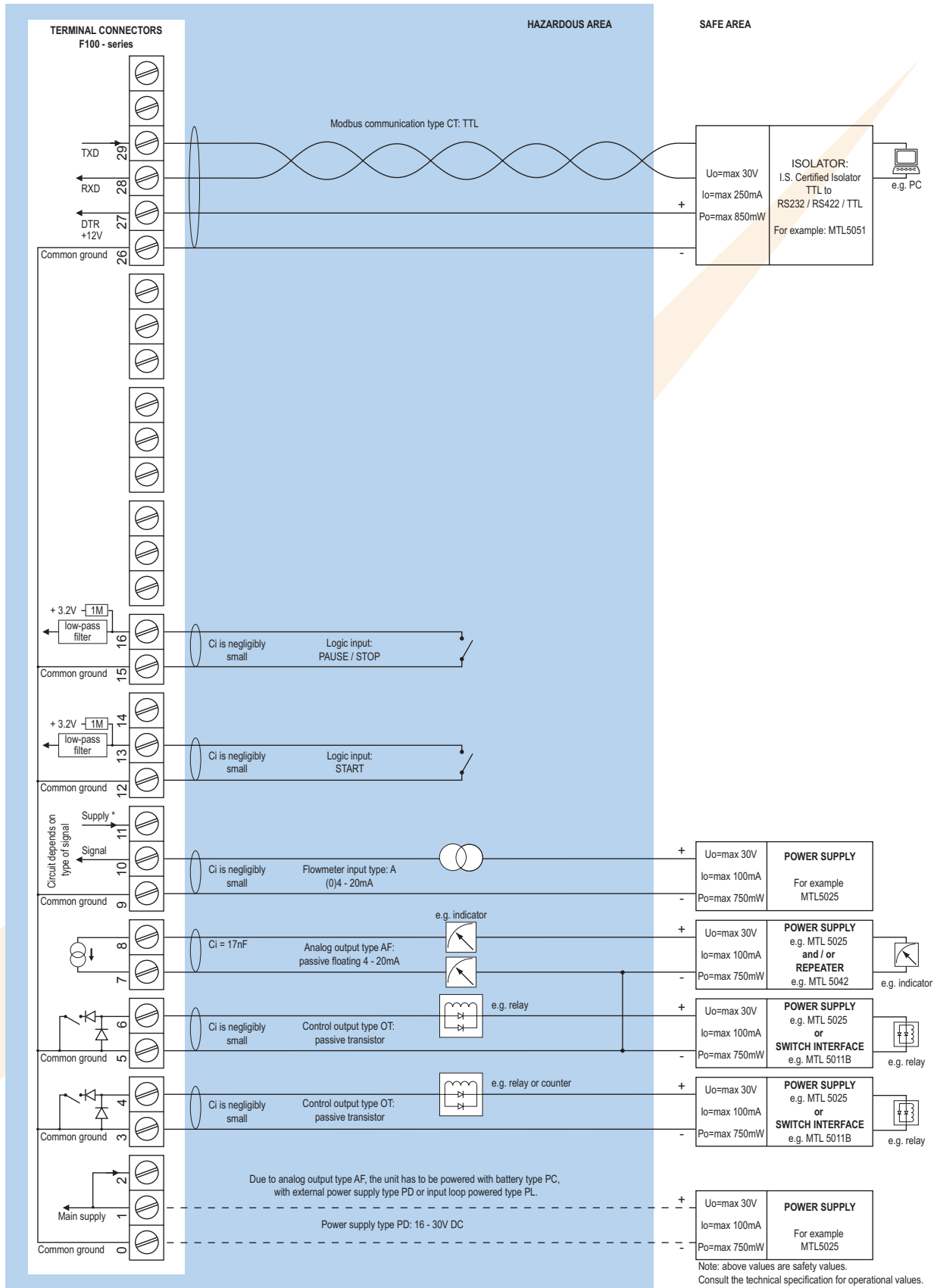

* Note power supply type PD: the supply voltage to pulse sensors is maximum 8.7V (U_o=max 8.7V I_o=max 25mA P_o=max 150mW) and to analog sensors as connected to terminal 1 (internally linked).

Technical specification

General

Display	
Type	High intensity reflective numeric and alphanumeric LCD, UV-resistant.
Dimensions	90 x 40mm (3.5" x 1.6").
Digits	Seven 17mm (0.67") and eleven 8mm (0.31") digits. Various symbols and measuring units.
Refresh rate	User definable: 8 times/sec. - 30 secs.
Option ZB	Transflective LCD with green LED backlight. Good readings in full sunlight and darkness.
Note	Only available for safe area applications.

Operating temperature

Operational	-30°C to +80°C (-22°F to +178°F).
Intrinsically Safe	-30°C to +70°C (-22°F to +158°F).

Power requirements

Type PB	Long life Lithium battery - life-time depends upon settings and configuration - up to 5 years.
Type PC	Intrinsically Safe long life lithium battery - life-time depends upon settings and configuration - up to 5 years.
Type PD	8 - 24V AC / DC ± 10%. Power consumption max. 10 Watt. Intrinsically Safe: 16 - 30V DC; power consumption max. 0.75 Watt.
Type PF	24V AC / DC ± 10%. Power consumption max. 15 Watt.
Type PL	Input loop powered from sensor signal 4 - 20mA (type "A") - requires types AI or AF and OT.
Type PM	115 - 230V AC ± 10%. Power consumption max. 15 Watt.
Type PX	8 - 30V DC. Power consumption max. 0.5 Watt.
Type ZB	12 - 24V DC ± 10% or type PD / PF / PM. Power consumption max. 1 Watt.
Note PB/PF/PM	Not available Intrinsically Safe.
Note PF/PM	The total consumption of the sensors and outputs may not exceed 400mA @ 24V.
Note	For Intrinsically Safe applications, consult the safety values in the certificate.

Sensor excitation

Type PB/PC/PX	3.2V DC for pulse signals and 1.2V DC for coil pick-up.
Note	This is not a real sensor supply. Only suitable for sensors with a very low power consumption like coils (sine wave) and reed-switches.
Type PD	1.2 - 3.2 - 8.2 - 12 and 24V DC - max. 50mA @ 24V DC.
Type PD-XI	1.2 - 3.2 - 8.2V DC - max. 7mA @ 8.2V DC and mains power supply voltage (as connected to terminal 1).
Note	In case PD-XI and signal A or U: the sensor supply voltage is according to the power supply voltage connected to terminal 1. Also terminal 2 offers the same voltage.
Type PF / PM	1.2 - 3.2 - 8.2 - 12 and 24V DC - max. 400mA @ 24V DC.



Terminal connections

Type	Removable plug-in terminal strip. Wire max. 1.5mm ² and 2.5mm ² .
------	---

Data protection

Type	EEPROM backup of all settings. Backup of running totals every minute. Data retention at least 10 years.
Pass-code	Configuration settings can be pass-code protected.

Hazardous area

Intrinsically Safe Type XI	ATEX approval ref.:  II 1 GD EEx ia IIB/IIC T4 T100°C. Maximum ambient +70°C (158°F).
Explosion proof Type XF	ATEX approval ref.:  II 2 GD EEx d IIB T5. Dimensions of enclosure: 300 x 250 x 200mm (11.8" x 9.9" x 7.9") L x H x D.
Weight	appr. 15 Kg.

Environment

Electromagnetic compatibility	Compliant ref: EN 61326 (1997), EN 61010-1 (1993).
-------------------------------	--

Casing

General

Window	Polycarbonate window.
Sealing	Silicone.
Control keys	Three industrial micro-switch keys. UV-resistant silicone keypad.
Option ZS	Silicone free ABS enclosure with EPDM and PE sealings. UV-resistant polyester keypad.
Note	This option comes with type HD only.

Aluminum wall / field mount enclosures

General	Die-cast aluminum wall/field mount enclosure IP67 / NEMA 4X with 2-component UV-resistant coating.
Dimensions	130 x 120 x 75mm (5.12" x 4.72" x 2.95") - W x H x D.
Weight	1064 gr.
Type HA	Cable entry: 2 x PG9 and 1 x M20.
Type HM	Cable entry: 2 x M16 and 1 x M20.
Type HN	Cable entry: 1 x M20.
Type HO	Cable entry: 2 x M20.
Type HP	Cable entry: 6 x M12.
Type HT	Cable entry: 1 x 1/2" NPT.
Type HU	Cable entry: 3 x 1/2" NPT.
Type HZ	Cable entry: no holes.

GRP wall / field mount enclosures

General	GRP wall/field mount enclosure IP67 / NEMA 4X, UV-resistant and flame retardant.
Dimensions	130 x 120 x 75mm (5.12" x 4.72" x 2.95") - W x H x D.
Weight	566 gr.
Type HD	Cable entry: no holes.
Type HE	Cable entry: 2 x Ø 16mm and 1 x Ø 20mm.
Type HF	Cable entry: 1 x Ø 22mm (0.866").
Type HG	Cable entry: 2 x Ø 20mm.
Type HH	Cable entry: 6 x Ø 12mm.

Panel mount enclosures

Dimensions	130 x 120 x 60mm (5.12" x 4.72" x 2.36") - W x H x D.
Panel cut-out	115 x 98mm (4.53" x 3.86") L x H.
Type HB	Die-cast aluminum panel mount enclosure IP65 / NEMA 4.
Weight	570 gr.
Type HC	GRP panel mount enclosure IP65 / NEMA 4, UV-resistant and flame retardant.
Weight	422 gr.

Signal inputs

Flowmeter

Type P	Coil / sine wave (minimum 20mVpp or 80mVpp - sensitivity selectable), NPN/PNP, open collector, reed-switch, Namur, active pulse signals 8 - 12 and 24V DC.
Frequency	Minimum 0Hz - maximum 7kHz for total and flow rate. Maximum frequency depends on signal type and internal low-pass filter. E.g. reed switch with low-pass filter: max. frequency 120Hz.
K-Factor	0.000010 - 9,999,999 with variable decimal position.
Low-pass filter	Available for all pulse signals.
Option ZF	coil sensitivity 10mVpp.
Type A	(0)4 - 20mA. Analog input signal can be scaled to any desired range within 0 - 20mA.
Type U	0 - 10V DC. Analog input signal can be scaled to any desired range within 0 - 10V DC.
Accuracy	Resolution: 14 bit. Error < 0.025mA / ± 0.125% FS. Low level cut-off programmable.
Span	0.000010 - 9,999,999 with variable decimal position.
Update time	Four times per second.
Voltage drop	Type A: 2.5V @ 20mA.
Load impedance	Type U: 3kΩ.
Relationship	Linear and square root calculation.
Note	For signal type A and U: external power to sensor is required; e.g. type PD.

Logic inputs

Function	Two terminal inputs to start, stop and reset the batch process.
Type	Internally pulled-up switch contact - NPN.
Duration	Minimum pulse duration 100msec.

Signal outputs

Analog output

Function	Transmitting flow rate.
Accuracy	10 bit. Error < 0.05%. Analog output signal can be scaled to any desired range.
Update time	Ten times per second.
Type AA	Active 4 - 20mA output (requires OA + PD, PF or PM).
Type AB	Active 0 - 20mA output (requires OA + PD, PF or PM).
Type AF	Passive floating 4 - 20mA output for Intrinsically Safe applications (requires PC, PL or PD).
Type AI	Passive galvanically isolated 4 - 20mA output - also available for battery powered models (requires PB, PD, PF, PL or PM).
Type AP	passive 4 - 20mA output - not isolated. Unit will be loop powered.
Type AU	Active 0 - 10V DC output (requires OA + PD, PF or PM).

Control / pulse output

Function	User defined: batch process one or two stage control - scaled pulse output according the running batch or according accumulated total.
Frequency	Max. 64Hz. Pulse length user definable between 7.8 msec up to 2 seconds.
Type OA	Two active 24V DC transistor outputs (PNP); max. 50mA per output (requires AA + PD, PF or PM).
Type OR	Two electro-mechanical relay outputs (N.O.) - isolated; max. switch power 230V AC - 0.5A per relay (requires PF or PM).
Type OT	Two passive transistor outputs (NPN) - not isolated.
Load	Max. 50V DC - 300mA per output.

Communication option

Function	Reading display information, reading / writing all configuration settings.
Protocol	Modbus RTU.
Speed	1200 - 2400 - 4800 - 9600 baud.
Addressing	Maximum 255 addresses.
Type CB	RS232
Type CH	RS485 2-wire
Type CI	RS485 4-wire
Type CT	TTL Intrinsically Safe.

Operational

Operator functions

Displayed functions	<ul style="list-style-type: none"> • Preset value - can be entered by the operator. • Batched quantity or remaining quantity. • Flow rate. • Total and accumulated total. • Total can be reset to zero by pressing the STOP-key twice.
---------------------	---

Preset / total

Digits	7 digits.
Units	L, m ³ , GAL, USGAL, KG, lb, bbl, no unit.
Decimals	0 - 1 - 2 or 3.
Note	Total can be reset to zero.

Accumulated total

Digits	11 digits.
Units / decimals	According to selection for total.
Note	Can not be reset to zero.

Flow rate

Digits	7 digits.
Units	mL, L, m ³ , Gallons, KG, Ton, lb, bl, cf, RND, ft ³ , scf, Nm ³ , NL, igal - no units.
Decimals	0 - 1 - 2 or 3.
Time units	/sec - /min - /hr - /day.

Display example - 90 x 40mm (3.5" x 1.6")

▲	ACTUAL	L
	2973.4	
	RUN	
RATE	7213.9	L/MIN

Ordering information

Standard configuration: F131-P-AP-CX-HC-OT-PX-XX-ZX.

Ordering information:	F131	-	A	-	C	-	H	-	O	-	P	-	X	-	Z
Flowmeter input signal															
A	⊗	(o)4 - 20mA input.													
P	⊗	Pulse input: coil, npn, pnp, namur, reed-switch.													
U	⊗	0 - 10V DC input.													
Analog output signal															
AA		Active 4 - 20mA output - requires OA + PD, PF or PM.													
AB		Active 0 - 20mA output - requires OA + PD, PF or PM.													
AF	⊗	I.S. floating 4 - 20mA output - requires PC, PD or PL.													
AI		Isolated 4 - 20mA output - requires PB, PD, PF, PL or PM.													
AP	⊗	Passive 4 - 20mA output, loop powered unit.													
AU		Active 0 - 10V DC output - requires OA + PD, PF or PM.													
Communication															
CB		Communication RS232 - Modbus RTU.													
CH		Communication RS485 - 2wire - Modbus RTU.													
CI		Communication RS485 - 4 wire - Modbus RTU.													
CT	⊗	Intrinsically Safe TTL - Modbus RTU.													
CX	⊗	No communication.													
Panel mount enclosures - IP65 / NEMA4															
HB	⊗	Aluminum enclosure.													
HC	⊗	GRP enclosure.													
GRP field / wall mount enclosures - IP67 / NEMA4X															
HD	⊗	Cable entry: no holes.													
HE	⊗	Cable entry: 2 x 16mm + 1 x 20mm.													
HF	⊗	Cable entry: 1 x 22mm (0.866").													
HG	⊗	Cable entry: 2 x 20mm.													
HH	⊗	Cable entry: 6 x 12mm.													
Aluminum field / wall mount enclosures - IP67 / NEMA4X															
HA	⊗	Cable entry: 2 x PG9 + 1 x M20.													
HM	⊗	Cable entry: 2 x M16 + 1 x M20.													
HN	⊗	Cable entry: 1 x M20.													
HO	⊗	Cable entry: 2 x M20.													
HP	⊗	Cable entry: 6 x M12.													
HT	⊗	Cable entry: 1 x 1/2" NPT.													
HU	⊗	Cable entry: 3 x 1/2" NPT.													
HZ	⊗	Cable entry: no holes.													
Outputs															
OA		Two active transistor outputs - requires AA, AB or AU and PD, PF or PM.													
OR		Two mechanical relay outputs - requires PF or PM.													
OT	⊗	Two passive transistor outputs - standard configuration.													
Power supply															
PB		Lithium battery powered.													
PC	⊗	Lithium battery powered - Intrinsically Safe.													
PD	⊗	8 - 24V AC/DC + sensor supply - with XI: 16 - 30V DC.													
PF		24V AC/DC + sensor supply.													
PL	⊗	Input loop powered from sensor signal type "A" - requires AF or AI and OT.													
PM		115 - 230V AC + sensor supply.													
PX	⊗	Basic power supply 8 - 30V DC (no real sensor supply). Unit requires external loop AP.													
Hazardous area															
XI	⊗	Intrinsically Safe.													
XF	⊗	EExd enclosure - 3 keys.													
XX		Safe area only.													
Other options															
ZB		Backlight.													
ZF	⊗	Coil input 10mVpp.													
ZS	⊗	Silicone free ABS enclosure with EPDM and PE sealings (type HD only).													
ZX	⊗	No options.													

The bold marked text contains the standard configuration.

⊗ Available Intrinsically Safe.

Specifications are subject to change without notice.

FLUIDWELL bv
P.O. Box 6
5460 AA - Veghel - The Netherlands
Tel.: +31 (0)413 343786
Fax.: +31 (0)413 363443
sales@fluidwell.com
Internet: www.fluidwell.com

