

Models  
64A  
65A



Model 64A



Model 65A

### Features

- The Models 64A and 65A Service Regulators are precision units used in instrumentation and general purpose applications.
- An Aspirator Tube compensates downstream pressure droop under flow conditions.
- A large Control Diaphragm area provides increased sensitivity.
- A full Flow Gage Port provides convenient pressure gage mounting.
- The Model 65 Standard 40-Micron Filter prevents particles from entering the output airstream.
- The Model 65 Filter Dripwell contains a Petcock Valve to easily drain trapped liquids.

### Operating Principles

When you adjust the Range Screw to a specific setpoint, the Range Spring exerts a downward force against the top of the Control Diaphragm. This downward force opens the Supply Valve. Output pressure flows through the Outlet Port and the Aspirator Tube to the Control Chamber where it creates an upward force on the bottom of the Control Diaphragm.

When the setpoint is reached, the force of the Range Spring that acts on the top of the Control Diaphragm balances with the force of output pressure that acts on the bottom of the Control Diaphragm and closes the Supply Valve.

When the output pressure increases above the set point, the Diaphragm Assembly moves upward to close the Supply Valve and open the Exhaust Valve. Output pressure flows through the Exhaust Valve and out of the Vent on the side of the unit until it reaches the setpoint. For more information, see cross sectional diagram.

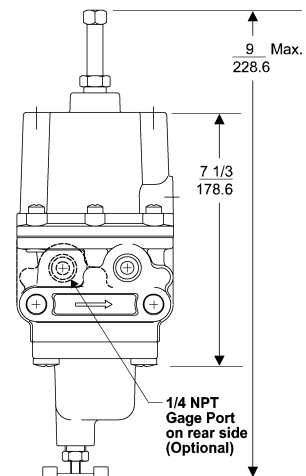
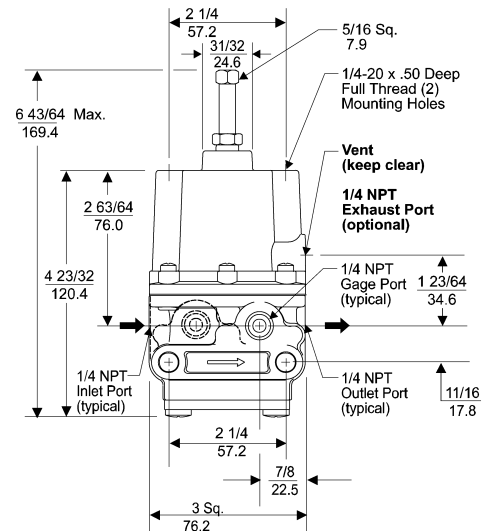
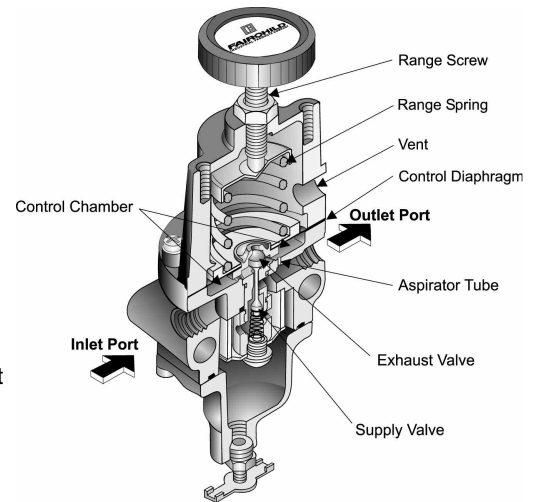

**Technical Information**

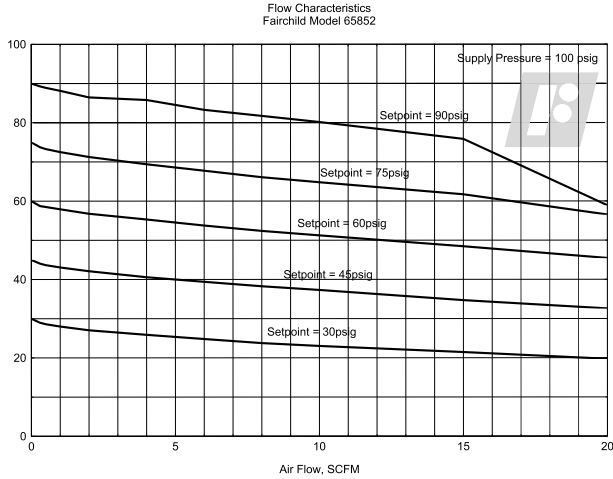

**Specifications**

**Supply Pressure**

300 psig, [21.0 BAR], (2100 kPa) Maximum

**Flow Capacity (SCFM)**

22 (37.4 m<sup>3</sup>/HR) @ 100 psig, [7.0 BAR], (700 kPa) supply & 20 psig, [1.5 BAR], (150 kPa) setpoint

**Exhaust Capacity (SCFM)**

1 (1.72 m<sup>3</sup>/HR) where downstream pressure is 5 psig, [.35 BAR], (35 kPa) above 20 psig, [1.5 BAR], (150 kPa) setpoint

**Supply Pressure Effect**

Less than 0.1 psig, [.007 BAR], (0.7 kPa) for 25 psig, [1.7 BAR], (170 kPa) change in supply pressure

**Sensitivity**

1" (2.50 cm) Water Column

**Ambient Temperature**

-40°F to +180°F, (-40°C to + 82°C)

**Materials of Construction**

Body and Housing .....Aluminum

Trim .....Zinc Plated Steel, Brass

Diaphragms .....Nitrile on Dacron

**Catalog Information**

**Catalog Number**

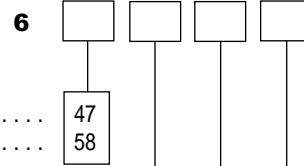

**Models**

64 .....  
65 .....

**Pressure Range**

psig	[BAR]	(kPa)	
0.5-30	[0.03-2]	(3-200)	3
1-60	[0.10-4]	(10-400)	4
2-120	[0.15-8]	(15-800)	5

**Pipe Size**

1/4" NPT ..... 2

**Options**

Tapped Exhaust .....	E
5 Micron Filter (65A Only) .....	F
Second Gage Port .....	G
BSPP (Parallel) <sup>1</sup> .....	H
Knob Adjust .....	K
Screened Vent .....	M
Tamper Proof .....	T
BSPT (Tapered) .....	U

<sup>1</sup>BSPP Threads in Inlet & Outlet Ports Only. Others BSPT.

**Installation**

For installation instructions, refer to the *Fairchild Model 64A, 65A Pneumatic Service Regulator Installation, Operation and Maintenance Instructions, IS-1064A65A.*