

**Principle of Operation**

Liquid enters a precision-machined chamber containing a disc which nutates (wobbles). The position of the disc divides the chamber into compartments containing an exact volume. Liquid pressure drives the disc to wobble and a roller cam causes the nutating disc to make a complete cycle. The compartments are filled and emptied each cycle. The movements of the disc are transmitted by a gear train to a register/totalizer or pulse transmitter. Close clearances between the disc and chamber ensure minimum leakage for accurate and repeatable measurement of each volume cycle.

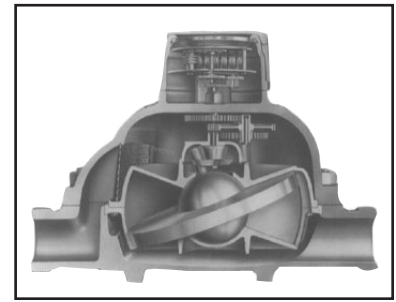

**Figure 1**



**Figure 2.** 1" Nutating Disc with R-25 transmitter



**Figure 3.** 1 1/2" Nutating Disc with R-10 register



**Figure 4.** 1" Nutating Disc with R-31 register

**Accessories**

- Rate of flow indicators
- Totalizers
- Transmitters
- Batch controllers

**Benefits**

Exceptional Value	Eliminates upstream and downstream straight run piping requirements Power not required for mechanical version
Saves Space	Very compact size
Fluid Compatibility	Various materials of construction makes flowmeter compatible with broad range of fluids

## Technical Information

### Functional Specifications

Fluid Types	Liquid
Maximum Pressure	See Table 3
Fluid Temperature	See Table 3
Registration	U.S. gallons, lbs., Imperial gallons, Liters, etc.
Outputs	Mechanical totalizing, mechanical batching, electro-mechanical totalizing, electro-mechanical batching, and blind electronic pulse registers available. See Registers section beginning on page 44.

### Performance Specifications

Accuracy	± 1.5% of rate over flow ranges of Table 2 - std. ± 0.5% of rate available (consult factory)
Repeatability	± 0.25% of rate
Flow Turndown Ratio	See Table 2
Agency Approvals	UL and CSA Class 1 Div 1 Group D Display and Totalizer Available

### Physical Specifications

<b>Materials of Construction</b> (see Table 3)	
Case	Bronze; 316 SS; or Teflon® coated Cast Iron or carbon steel
Chamber Material	Bronze; Ni-resist; or 316 SS
Disc	Ryton®
Ball	Ryton® or carbon
Seal	Nitrile or Teflon® with 316 SS chamber
Gears	Bronze or 316 SS with 316 SS chamber
Register Housing	Plastic, Bronze, Aluminum - See section beginning on page 44
<b>Connections &amp; Mountings</b>	
Mounting Position	Horizontal Ensure meter remains full with register up.
Typical Straight Pipe Requirements	Upstream: none Downstream: none
Process Connections	MNPT
Electrical Connection	Only for optional electronic transmitter

## Sizing and Ordering Information

Please provide completed application data sheet (found at [www.aaliant.com](http://www.aaliant.com)) to allow us to confirm selection.

1. Confirm fluid viscosity at process temperature and select Group category from Table 1 and Table 4.
2. Confirm minimum and maximum flow ranges to maintain stated accuracy for Group category from Table 2 are within your requirements.
3. Move horizontally across the row of Table 2 until you reach desired case materials of construction compatible with process fluid. See Table 4 for additional information.
4. Select line size identified from #3 above.
5. Select materials of construction for case, chamber, disc and ball using Table 3 and Table 4.
6. Confirm maximum pressure capability of meter at process temperature per Table 3. Confirm pressure drop across the meter using Figure 5 does not exceed system requirements.
7. Select drive type from Table 2.
8. Select Register/Transmitter from page 5.
9. Specify Register/Transmitter units of measure (gallons, pounds, liters, etc.)

## Flow Rate Group

Group 1	Up to 30 SSU (.20 to 1.00 centipoise)
Group 2	31 to 450 SSU (1 to 90 centipoise)
Group 3	450 to 1,000 SSU (90 to 220 centipoise)
Group 4	1,000 to 5,000 SSU (220 to 1,100 centipoise)
Group 5	5,500 to 20,000 SSU (1,100 to 4,400 centipoise)
Group 6	20,000 to 50,000 SSU (4,400 to 11,000 centipoise)

Table 1

## Flow Ranges

Minimum and maximum flow rates in gpm to achieve accuracy

Flow Rate Group (flow rates in GPM)						High Pressure Teflon® Coated Carbon Steel with Mechanical Drive	Teflon® Coated Cast Iron with Mechanical Drive	Bronze with Mechanical Drive	Bronze with Magnetic Drive	316 SS with Mechanical Drive
1	2	3	4	5	6					
0.75 - 5	0.5 - 7	0.2 - 5	0.2 - 5	0.2 - 3		—	¾" MNPT	¾" MNPT	¾" MNPT	—
1 - 11	1 - 20	1 - 15	1 - 8	1 - 4		1" MNPT	1" MNPT	1" MNPT	—	1" MNPT
3 - 18	2 - 30	3 - 20	1 - 12	1 - 6	0.5 - 4	—	1 ¼" MNPT	1 ¼" MNPT	—	—
5 - 30	3 - 50	5 - 30	2 - 15	1 - 8	1 - 5	1 ½" Flg.	1 ½" MNPT	1 ½" MNPT	—	1 ½" Flg.
7 - 35	5 - 100	7 - 50	2 - 35	2 - 20	1.5 - 10	—	2" MNPT	2" MNPT	—	—
12 - 65	8 - 160	12 - 100	5 - 70	5 - 40	2 - 20	2 ½" Flg.	2 ½" MNPT	—	—	2 ½" Flg.
18 - 100	8 - 240	15 - 125	9 - 80	9 - 45	4 - 25	—	—	3" G Flg.	—	—
22 - 120	15 - 300	25 - 180	12 - 110	12 - 60	10 - 30	—	—	3" I Flg.	—	—
35 - 185	20 - 400	30 - 250	16 - 190	16 - 100	14 - 50	—	—	4" Flg.	—	—

Table 2

### Temperature/Pressure Ratings

<b>Bronze - Case Material</b>										
Chamber Materials		Bronze Standard								
Drive		Magnetic			Mechanical					
Size		¾"	1"	1 ½"	2"	3" G	3" I	4"		
Temp. & Pressure (in psi)	100° F	150	200	225	250	225	225	150		
	200° F	135	185	210	235	200	210	135		
	300° F	115	165	195	215	175	185	110		
	400° F	100	150	175	200	150	160	85		
End Connections		MNPT	MNPT	MNPT	MNPT	Flg.	Flg.	Flg.		
<b>Teflon® Coated Cast Iron - Case Material</b>										
Chamber Materials		Bronze Standard						Ni-resist (opt.)	Stainless steel(opt.)	
Size		¾"	1"	1 ¼"	1 ½"	2"	2 ½"	1 ¼"	1"	1 ½"
Temp. & Pressure (in psi)	100° F	150	300	250	250	250	175	250	300	250
	200° F	135	285	235	235	235	160	235	285	235
	300° F	115	265	215	215	215	140	215	265	215
	400° F	100	250	200	200	200	125	200	250	200
End Connections		MNPT	MNPT	MNPT	MNPT	MNPT	MNPT	MNPT	MNPT	MNPT
<b>Teflon® Coated Cast Iron - Case Material High Pressure Ink Meter</b>										
Chamber Materials		Bronze								
Size		1"								
Temp. & Pressure (in psi)		5000								
End Connections		MNPT								
<b>High Pressure Teflon® Coated Carbon Steel</b>										
Chamber Materials		Steel			Steel			Steel		
Size		1"			1 ½"			2½"		
Temp. & Pressure (in psi)	100° F	1440			720			720		
	200° F	1400			700			700		
	300° F	1365			680			680		
	400° F	1330			665			665		
End Connections		MNPT			Flg.			Flg.		
<b>Stainless Steel - Case Material</b>										
Chamber Materials		Steel			Steel			Steel		
Size		1"			1 ½"			2½"		
Temp. & Pressure (in psi)	100° F	150			150			150		
	200° F	130			130			130		
	300° F	115			115			115		
	400° F	100			100			100		
End Connections		MNPT			Flg.			Flg.		

Table 3

## Registers/Transmitters

### Model # Description

R-10	Horizontal, mechanical, non-resettable total (See Note 1)
R-11	Blind transmitter with dry contact closure (See Note 2)
R-15A	Horizontal, mechanical, non-resettable total (See Note 3)
R-15B	Horizontal, mechanical w/ transmitter, non-resettable total with contact closure (See Note 3)
R-20	Vertical, mechanical non-resettable with 6" dial (See Note 2)
R-22A	Vertical, mechanical totalizer and resettable totalizer (See Note 2)
R-22B	Vertical, mechanical w/ transmitter, totalizer and resettable totalizer with contact closure (See Note 2)
R-22C	Vertical, mechanical w/ transmitter, totalizer and resettable totalizer with digital pulse, explosion proof (See Note 2)
R-25	Blind transmitter with digital pulse explosion proof (See Note 1)
R-30A	Vertical, mechanical w/ transmitter, non-resettable total, 6" dial, contact closure at batch (See Note 2)
R-30C	Vertical, mechanical w/ transmitter, non-resettable total, 6" dial, contact closure at zero point (See Note 2)
R-30D	Vertical, mechanical w/ pulse transmitter, non-resettable total, 6" dial, contact closure per unit (See Note 2)
R-31C	Vertical, mechanical w/ transmitter, non-resettable total, 6" dial, contact closure at zero, explosion proof (See Note 2)
R-35	Mechanical batch controller with bronze or stainless steel valve (See Note 4)

**Note 1:** Not available with 3/4" bronze case meters.

**Note 2:** Not available with 3/4" meters.

**Note 3:** Not available with 3/4" Teflon® coated cast iron case meters.

**Note 4:** Only available with 1 - 2" Teflon® coated cast iron case and bronze case flowmeters and 1 - 1 1/2" stainless steel case meters.

## Pressure Drops

To find the pressure loss through a Niagara meter for a given application use the formula below.

$$\text{Pressure drop} = (\text{Step 1}) \times (\text{Step 2})$$

**Step 1.** Find your liquid's viscosity (SSU value)\*\* on the horizontal scale in the graph (Fig. 1). Draw a vertical line up to the conversion line. From that point on the curve, draw a horizontal line over to the vertical scale.

**Step 2.** Locate the meter size in the first column of the nomograph\* at right. Then locate the meter flow rate in the second column. Draw a straight line through these two points and over to the third column. This point at which your line intersects the third column is the pressure loss through the meter when measuring water. Multiply the resulting viscosity pressure loss factor by the pressure loss obtained in the nomograph. This value is the approximate pressure loss for your application.

\*Based on average from test of stock Niagara meter when measuring water.

\*\*Consult factory for liquids above 10,000 SSU.

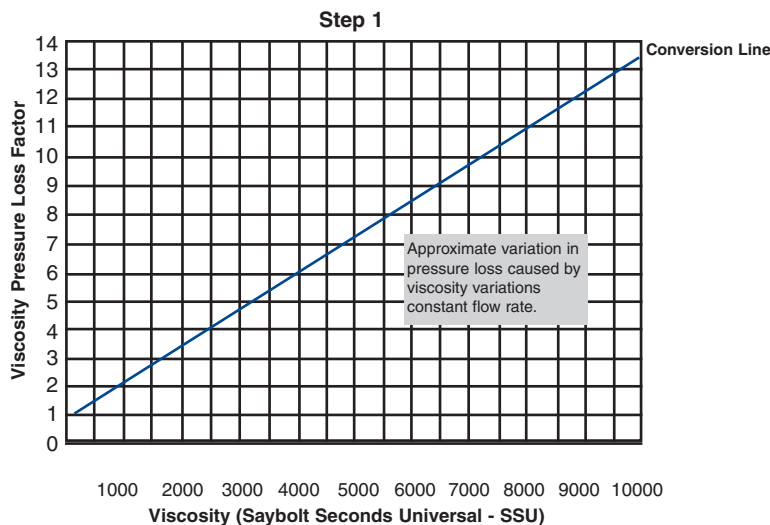
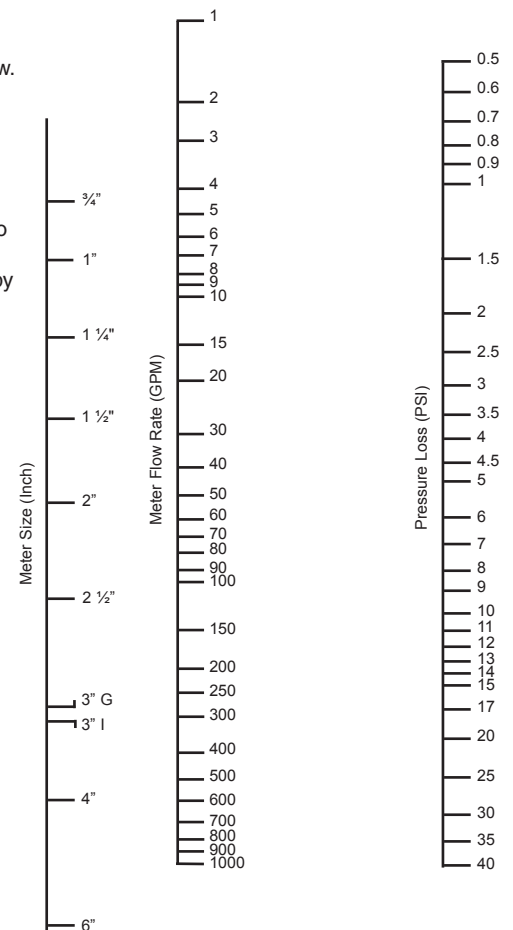

Figure 5

### Step 2 Nomograph



## Material Selection Guide

Liquid	Flow rate group	Case material	Chamber material	Disc/ball material
Acetic Acid	2	SS	SS	ryton/carbon
Acetic Anhydride	2	SS	SS	ryton/carbon
Alcohol (denatured)	1	bronze iron	bronze bronze	ryton/carbon ryton/carbon
Alcohol (ethyl/methyl)	1	bronze	bronze	ryton/carbon
Aluminum Sulphate 50%	2	SS	SS	ryton/carbon
Ammonium Nitrate	2	iron SS	SS	ryton/carbon
Ammoniumj Phosphate	2	SS	SS	ryton/carbon
Animal fat	3	iron	ni-resist SS	ryton/ryton ryton/carbon
Apple Juice	2	SS	SS	ryton/carbon
Asphalt (mastic) for sizes 2 1/2" up	6	iron	bronze	ryton/ryton
Brine (sodium)	2	bronze	bronze	ryton/ryton
Bunker C oil	5	iron	bronze	ryton/ryton
Buttermilk (cattle feed)	2	bronze iron	bronze bronze	ryton/ryton ryton/ryton
Calcium chloride 30%	2	iron	SS	ryton/carbon
Casein	2	iron	bronze	ryton/carbon
Caustic soda	2	iron SS	ni-resist SS	ryton/ryton ryton/carbon
Citrus fruit juices	2	SS	SS	ryton/carbon
Core oil	3	iron	bronze	ryton/ryton
Corn oil	3	iron	ni-resist SS	ryton/ryton ryton/carbon
Corn syrup	6	iron	bronze	ryton/ryton
Creosote	4	bronze iron	bronze bronze	ryton/ryton ryton/ryton
Cutting oil	4	bronze iron	bronze bronze	ryton/ryton ryton/ryton
DDT solution	1	iron	bronze	ryton/carbon
Distilled water	1	SS	SS	ryton/carbon
Emulsion oil & water	5	bronze iron	bronze bronze	ryton/ryton ryton/ryton
Ether	1	iron	SS	ryton/carbon
Ether, (ethyl)	1	SS	SS	ryton/carbon
Ethylene diamine	3	SS	SS	ryton/carbon
Ethylene glycol	2	iron	bronze	ryton/ryton
Ferric sulphate solution	1	SS	SS	ryton/carbon
Fish oil	3	iron	bronze	ryton/ryton
Fish solubles	2	bronze iron	bronze bronze	ryton/ryton ryton/ryton
Formaldehyde	1	SS	SS	ryton/carbon
Fuel oil #1 & 2	2	iron	bronze	ryton/ryton
Fuel oil #3 & 4	3	iron	bronze	ryton/ryton
Fuel oil #5 & 6	4	iron	bronze	ryton/ryton
Gasoline	1	bronze iron	bronze bronze	ryton/carbon ryton/carbon
Glue	6	iron	bronze	ryton/ryton
Glycerine	2	bronze iron	bronze bronze	ryton/ryton ryton/ryton
Grease	6	iron	bronze	ryton/ryton
Kerosene	1	bronze iron	bronze bronze	ryton/ryton ryton/ryton
Lacquer	3	iron	bronze	ryton/ryton
Lactic acid	2	SS	SS	ryton/carbon
Lard (molten)	3	iron	ni-resist SS	ryton/ryton ryton/carbon
Latex solution	6	iron	bronze	ryton/ryton
Liquid soap solution	2	iron	SS	ryton/carbon
Malt syrup	3	bronze	bronze	ryton/ryton

Liquid	Flow rate group	Case material	Chamber material	Disc/ball material
Methyl ethyl ketone (MEK)	1	iron	SS	ryton/carbon
Mineral oil	2	iron	bronze	ryton/ryton
Mineral spirits	1	iron	bronze	ryton/carbon
Molasses (cold)	6	iron	bronze	ryton/ryton
Molasses (hot)	5	iron	bronze	ryton/ryton
Monochlorobenzol	1	bronze	bronze	ryton/ryton
Naptha	1	iron	bronze	ryton/ryton
Oil (soluble cutting)	2	iron	bronze	ryton/ryton
Oleic acid (red oil)	2	iron	ni-resist SS	ryton/ryton ryton/carbon
Paint (oil base)	3	iron	bronze	ryton/ryton
Paracol wax	3	iron	bronze	ryton/ryton
Paraffin (molten)	3	iron	bronze	ryton/ryton
Phenol	2	SS	SS	ryton/carbon
Phenolic resin	6	iron	bronze	ryton/ryton
Printing ink	6	iron	bronze	ryton/ryton
Resin emulsion	4	iron	bronze	ryton/ryton
Resin polyester	3	iron	bronze	ryton/ryton
Resin size	3	bronze	bronze	ryton/ryton
Rubber cement	6	iron	bronze	ryton/ryton
Soap	2	iron	bronze	ryton/ryton
Soap (resin)	3	iron	bronze	ryton/ryton
Sodium silicate	6	bronze iron	bronze bronze	ryton/ryton ryton/ryton
Stoddard solvent	1	iron	bronze	ryton/carbon
Sugar (liquid)	2	bronze iron	bronze bronze	ryton/ryton ryton/ryton
Sugar cane juice	2	bronze	bronze	ryton/ryton
Thinners	1	bronze iron	bronze bronze	ryton/carbon ryton/carbon
Toluene	1	bronze iron	bronze bronze	ryton/carbon ryton/carbon
Trichlorethylene	1	iron	bronze	ryton/carbon
Turpentine	2	iron	bronze	ryton/carbon
Vanilla extract	2	iron	bronze	ryton/ryton
Varsol	1	iron	bronze	ryton/carbon
Vegetable fat or oil	2	iron	ni-resist SS	ryton/ryton ryton/carbon
Vinegar	2	SS	SS	ryton/carbon
Water 100 to 180° F	3	bronze iron	bronze bronze	ryton/ryton ryton/ryton
Water 100° F	2	bronze iron	bronze bronze	ryton/ryton ryton/ryton
Water 180° F & above	4	bronze iron	bronze bronze	ryton/ryton ryton/ryton
Water, deionized, cold	2	SS	SS	ryton/carbon
Water, deionized, hot	1	SS	SS	ryton/carbon
Water, gas, tar	4	bronze iron	bronze bronze	ryton/ryton ryton/ryton
Wax (hot)	1	iron	bronze	ryton/ryton
Wax emulsion	2	iron	bronze	ryton/ryton
Whey	2	bronze iron	bronze bronze	ryton/ryton ryton/ryton
Xylol (xylene)	1	iron	bronze	ryton/carbon

Table 4

## Bronze Case

Model # N - - - -

Line Size \_\_\_\_\_

075 .....0.75" (See Note 1)

100 .....1.0"

125 .....1.25"

150 .....1.5"

200 .....2.0"

250 .....2.5"

300 G .....3.0"

300 I .....3.0"

400 .....4.0"

Case Material and Mounting Connections \_\_\_\_\_

BR N .....Bronze MNPT (0.75" to 2.5")

BR F .....Bronze 150# Flange (3.0" & 4.0")

Chamber Material \_\_\_\_\_

BR .....Bronze

Disc & Ball \_\_\_\_\_

1 .....Ryton®/Ryton®

Drive Type \_\_\_\_\_

A .....Magnetic (N075-BRN-BR1A only)

E .....Mechanical

**Note 1:** Only available in magnetic drive with R-15A or R-15B registers.

## Teflon® Coated Cast Iron Case

Model # N - - - -

Line Size \_\_\_\_\_

075 .....0.75" (See Note 1)

100 .....1.0"

125 .....1.25"

150 .....1.5"

200 .....2.0"

250 .....2.5"

Case Material and Mounting Connections \_\_\_\_\_

IR N .....Iron (Teflon® Coated) MNPT

Chamber Material \_\_\_\_\_

BR .....Bronze

NR .....Ni-Resist (1.25" only)

SS .....Stainless Steel (1.0" only)

SS .....Stainless Steel (1.5" only)

SS .....Stainless Steel (2.5" only)

Disc & Ball \_\_\_\_\_

1 .....Ryton®/Ryton®

2 .....Ryton®/Carbon (Stainless Steel chamber only)

Drive Type \_\_\_\_\_

E .....Mechanical

**Note 1:** Only available with R-10 and R-25 registers

## High Pressure Teflon® Carbon Steel Case

Model # N - - - -

Line Size \_\_\_\_\_

100 .....1.0"

150 .....1.5"

250 .....2.5"

Case Material and Mounting Connections \_\_\_\_\_

HC N .....Carbon Steel (Teflon® Coated 1.0" only) MNPT

HI N .....Iron "INK" (Teflon® Coated 1.0" only) MNPT

HC F .....Carbon Steel (Teflon® Coated 1.5" & 2.5" only) 300# Flange

Chamber Material \_\_\_\_\_

BR .....Bronze

SS .....Stainless Steel

Disc & Ball \_\_\_\_\_

1 .....Ryton®/Ryton®

2 .....Ryton®/Carbon (Stainless Steel chamber only)

Drive Type \_\_\_\_\_

E .....Mechanical

## Stainless Steel Case

Model # N - - - -

Line Size \_\_\_\_\_

100 .....1.0"

150 .....1.5"

250 .....2.5"

Case Material and Mounting Connections \_\_\_\_\_

SS N .....Stainless Steel (1.0" & 1.5") MNPT

SS F .....Stainless Steel (2.5" only") 150# Flange

Chamber Material \_\_\_\_\_

SS .....Stainless Steel

Disc & Ball \_\_\_\_\_

2 .....Ryton®/Carbon

Drive Type \_\_\_\_\_

E .....Mechanical