

ELECTRO OPTIC CONTROLLERS for use with LEVELITE electro optic probes

General Specifications

- AC: 120 or 240V (50/60 Hz), 1.4 VA
- DC: 12 or 24V (-25 to +15%), 1.8 W
- Accepts electro optic probes or customer supplied float switches
- 10 A, SPDT relays (1/3 hp @ 120 VAC)
- 1-60 second time delay adjustment
- High or low level failsafe adjustment
- LED alarm status indicator
- Polycarbonate enclosure

Electro Optic Level Switch Controller, One Channel

Levelite's perfect choice for simple "one switch" applications.

- Protect pumps and warn of "dry" running
- Prevent overflow or warn of material shortage
- Time based filling and emptying

Description	Part Number
120VAC	GLL101S1N
240VAC	GLL101S2N
12VDC	GLL101S3N
24VDC	GLL101S4N



GLL101S1N

Electro Optic Level Switch and Pump Controller, Two Channel

Increase flexibility with our Two Channel Controller Systems

- Provides dual alarms
- Automatically directs pump up or pump down operation

Description	Part Number
120VAC	GLL102S1N
240VAC	GLL102S2N
12VDC	GLL102S3N
24VDC	GLL102S4N



GLL102S2N

Dimensional Drawing

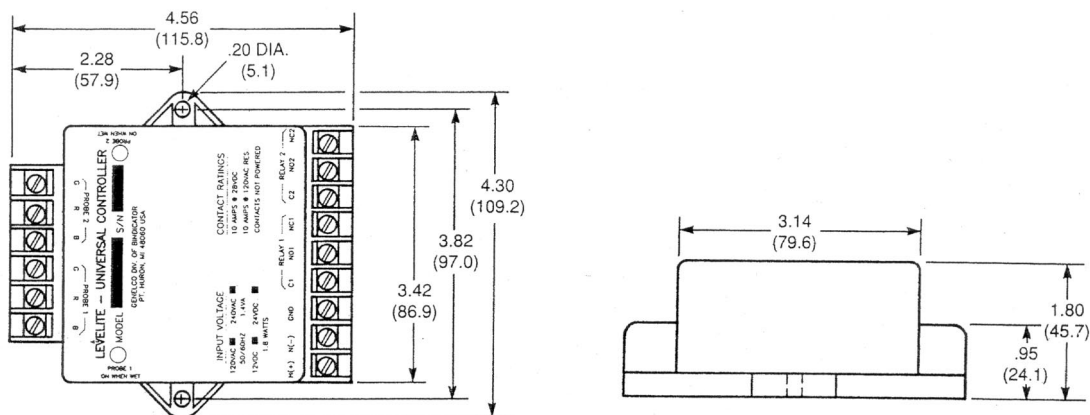

ELECTRO OPTIC PROBES

for use with LEVELITE electro optic controllers

Detect leaks, protect pumps and prevent spills with Levelite's miniature Electro Optic Level Sensors for OEM systems.

General Specifications

- Operates with all electro optic controllers
- Repeatability: 0.5 mm
- Includes 25' (7.62m) PVC jacketed cable (user extendable)
- 1/2" NPT process and conduit connections

A Popular Industry Choice for...

- Ultrapure water and water treatment
- Semiconductor and Pharmaceutical manufacturing
- Laboratory testing and chemical dispensing systems
- Leak detection in electronic enclosures, dual containment piping, and diked areas
- Beverages, chemicals, acids, caustics, water, epoxys, lubricants, glycols, vegetable oils, adhesives and solvents

Versatility is the key to Levelite's Electro Optic Level Sensors. Ideal for controlling any transparent or translucent liquid.

- Compact sensors fit anywhere
- PFA Teflon® probe for all high purity and corrosive liquids
- Detects liquids regardless of conductivity, color or specific gravity
- Eliminates pump cavitation when installed in advance of the pump
- Automatic pump control and high or low alarms

GLL110000 ▼ Polysulfone Electro Optic Probe

This probe is preferred for most oil, water and mildly corrosive applications.

- LEVELITE'S lowest priced probe
- Operating Temperature: -20° F to 200° F (-29° C to 94° C)
- Max Pressure: 100 psig (7kg/cm²)



GLL110000

GLL110118 ▼ Polysulfone Electro Optic Sanitary Probe

Ideal for applications in the food and pharmaceutical industries.

- 1 1/2" Tri-Clover type flange for CIP/other sanitary applications
- 1/2" NPT conduit connection
- Operating Temperature: -20° F to 200° F (-29° C to 94° C)
- Max Pressure: 100 psig (7kg/cm²)



GLL110118

GLL110010 ▼ PFA Teflon® Electro Optic Probe

Our best sensor for any corrosive or high purity liquid. Widely used in manufacturing of semiconductors, high purity liquids, ultrasonic cleaning and photography.

- Widely used in corrosive liquids
- Made from non-stick Teflon® to prevent coating
- Operating Temperature: -20° F to 200° F (-29° C to 94° C)
- Max Pressure: 100 psig (7kg/cm²)



GLL110010

ELECTRO OPTIC PROBES (cont'd)

for use with LEVELITE electro optic controllers

LEVELITE's quartz tip electro optic probes are designed for use with quartz tips (see below). The quartz tips are excellent for high pressure or high temperature applications, and also provide excellent corrosion resistance to many chemicals and solvents. The Teflon® light guide on the probe tip concentrates the light coming through the probe for greater signal strength.

Order probe and quartz tip separately.

GLL110020 ▼ Polypropylene Quartz Tip Electro Optic Probe

- Excellent for high level applications
- Quartz sensing tips built to your length specification. Order separately
- Operating Temperature: -20° F to 50° F (29° C to 65° C)
- Max Pressure: 100 psig (7kg/cm²)



GLL110020

shown with Quartz tip

GLL110021 ▼ 316 SS Quartz Tip Electro Optic Probe

- Excellent for high level applications
- Quartz tip length built for your application. Order separately.
- Operating Temperature: -20° F to 212° F (-29° C to 100° C)
- Max Pressure: 500 psig (35 kg/cm²)



GLL110021

shown with Quartz tip

Quartz Tips

- 5/8" to 10" Insertion Length
- Rulon® Seal
- Teflon® Light Guide
- Viton® O-Ring

GLL numbers increase by 10 with every inch (25.4mm). No half sizes.

Description	Part Number
5/8" (15.88mm)	GLL111000
1" (25.4mm)	GLL111010
2" (50.8mm)	GLL111020
3" (76.2mm)	GLL111030
4" (101.6mm)	GLL111040
5" (127mm)	GLL111050
6" (152.4mm)	GLL111060
7" (177.8mm)	GLL111070
8" (203.2mm)	GLL111080
9" (228.6mm)	GLL111090
10" (254mm)	GLL111100

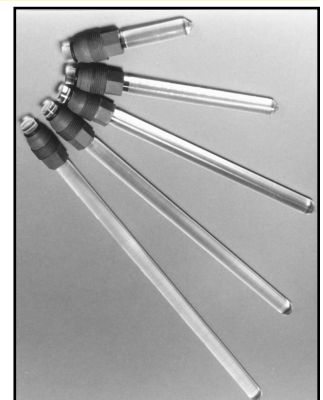

Quartz Tips