

Process & Temperature Digital Panel Meter

TRIDENT Model PD765



- 4-20 mA, ± 10 V, TC & RTD Inputs
- NEMA 4X, IP65 Front
- Shallow Depth Case 3.6" Behind Panel
- Universal Power Supply 85-265 VAC
- Two Relays Option with Alternation & Time Delays
- 4-20 mA Analog Output Option
- 24 VDC @ 200 mA Transmitter Power Option
- RS-232, RS-422/485 Serial Communication Options
- Modbus[®] RTU Option & Free LabVIEW[™] Driver
- Sunlight Readable Display
- 3 Year Warranty

PRECISION DIGITAL CORPORATION

**PRECISION
DIGITAL** 

www.predig.com

EASY SETUP & PROGRAMMING

The Trident is easily setup and programmed using the simple four-button programming method. There is only one switch on the entire meter, no jumpers, and no need to ever open the case. The meter can also be programmed using a PC and Precision Digital's MeterView software or "cloned" with the Copy function.

Front Panel Buttons



User Friendly Menu Structure

To simplify programming, the Trident's setup functions are divided into two menus. A main menu handles all the basic setup functions. An advanced features menu handles the special functions not commonly used.

Try the VirtualMeter at www.predig.com for an interactive demonstration of how the Trident is programmed.

- Press the **Menu** button to enter or exit the Programming Mode at any time.
- Press the **Right** arrow button to move to the next digit during digit programming.
- Press the **Up** arrow button to scroll through the menus, decimal point, or to increment the value of a digit.
- Press the **Enter/Ack** button to access a menu, accept a setting, or to acknowledge relays.

Setting Numeric Values

The numeric values are set using the **Right** and **Up** arrow buttons. Press the **Right** arrow button to select next digit and the **Up** arrow button to increment digit value.

The digit being changed is displayed brighter than the rest.

Press the **Enter/Ack** button, at any time, to accept a setting or **Menu** button to exit without saving changes.

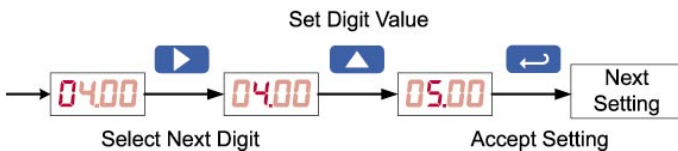

Main Menu

The main menu consists of the three most commonly used functions: **Setup**, **Program**, and **Password**. Press **Menu** button to enter the Programming Mode then press **Up** arrow button to scroll main menu.

The **Setup** menu is used to select the input signal, decimal point, °F or °C, and relay setup. The **Program** menu is used to calibrate or scale the meter. The **Password** menu is used to program a password.

The display moves to the next menu after the **Enter/Ack** button is pressed.

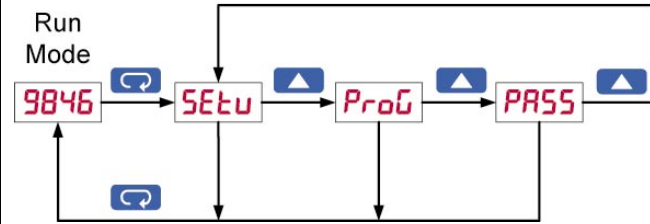

Advanced Features Menu

To simplify the setup process, the features least used in most applications are located in the *Advanced Features* menu.

To access the *Advanced Features* menu, Press and hold the **Right** arrow button first and then press the **Menu** buttons for three seconds.

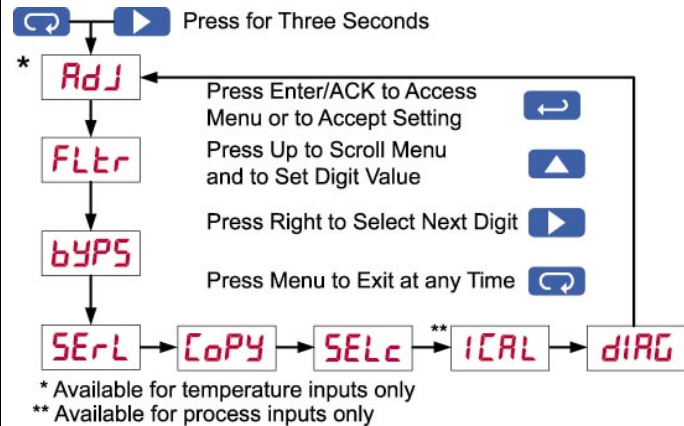

Offset Adjustment (AdJ)

This function allows the user to select an offset adjustment to the temperature being displayed. This value can be either positive or negative and can be any number within +/-19.9°.

Noise Filter (FLtR)

This function averages any minor or quick changes in the input signal and displays the reading with greater stability.

Noise Filter Bypass (bYPS)

The meter can be programmed to filter small input changes (with noise filter function), but allow larger input changes to be displayed immediately by setting the noise filter bypass function accordingly. If the change in input signal exceeds the bypass value, no filtering will occur and the new value will be displayed immediately.

Serial Communication (SErL)

This menu is used to program the serial communication parameters such as the address for each meter when used in a multi-drop mode.

The meter is equipped with serial communications capability as a standard feature using PDC Serial Communication Protocol. The Modbus RTU Protocol is optional and can be purchased at any time.

Protocol Selection Menu (PrOt)

The Protocol selection menu is used to select either the PDC or the Modbus protocol. If Modbus option is purchased separately, it is necessary to enter a four-digit code to enable the Modbus protocol.

Modbus® RTU Option

Free LabVIEW Driver

Meter Copy (COPy)

The Copy function is used to copy (or clone) all the settings from one Trident meter to other Trident meters

In less than 10 seconds!

The Copy function is a standard feature on all meters. The Copy feature does not require a serial communication adapter, it only requires the optional cable assembly (PDA7420), see the ordering information for complete details.



Select Menu (SELC)

The *Select* menu is used to select linear or square root function, display intensity, and low-flow cutoff. Selection for relay or analog output is a factory setting depending on the option installed.

Display Intensity Menu (INtY)

The Display *Intensity* function allows the selection of eight user selectable levels of intensity to help compensate for various lighting conditions, including direct sunlight.

**Sunlight Readable Display
is a Trident Standard Feature!**

Diagnostic Menu (d iAG)

The *Diagnostic* function aids in troubleshooting by providing a convenient way to review setup and programming parameters.

VERSATILE OPERATION

Look to the Trident meter for the key features and options you want and don't worry about getting bogged down in a confusing array of things you don't need. The Trident's *Max/Min* function, 2 relays, and serial communication options provide all the utility you need to handle all the common applications.

Powerful Relay Functionality

All relay functions are set up from the front panel or from a PC running MeterView® or LabView™ software.

- Automatic reset only
- Automatic or manual reset
- Latching or non-latching relays
- Pump alternation control
- On and off time delays from 0 to 199 seconds
- Fail-safe operation is user selectable

Maximum/Minimum Readings

To display the maximum and minimum readings since the last reset/power-up, use the Up arrow/Max button

Serial Communication Adapters



The Trident can be used as a data acquisition device, with the added benefit of a digital display, by connecting an optional RS-232 or RS-422/485 serial communication adapter. Precision Digital also provides the software needed for simple data acquisition and to program the meter.

QUICK INSTALLATION

The Trident is housed in a shallow-depth case that is designed for easy installation and servicing. The extra large front bezel is rated Type 4X, IP65. The mounting brackets are locked in place to make it easy to mount the meter in the panel. Removable screw terminal connectors make for easy and convenient wiring.

Mounting Dimensions

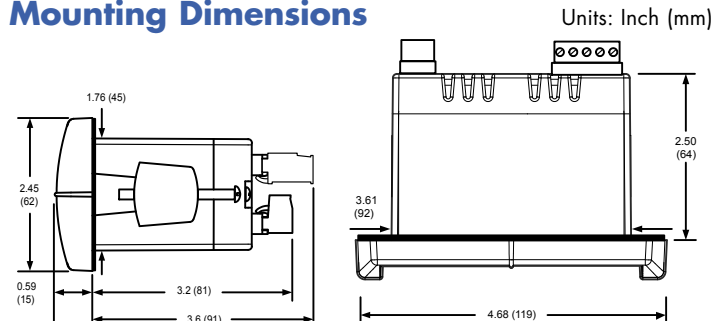

Notes:

1. Panel cutout required: 1.772 x 3.622 (45 x 92)
2. Panel thickness: 0.040 – 0.250 (1.0 – 6.4)
3. Mounting brackets lock in place for easy mounting

METERVIEW® SOFTWARE

Precision Digital's MeterView® software allows the Trident to be programmed from a PC and to act as a data logger.



- Program or read meter settings
- Save meter profiles for cloning
- Use profiles for reporting

SPECIFICATIONS

Precision Digital's MeterView® software enables programming the PD765 Trident meter from a PC, displaying the readings of up to 100 Precision Digital meters, and data logging of all meters to a file. MeterView® may be used for monitoring and data logging applications.

- System Requirements:** Windows® 95/98/ME/NT4/2000/XP
- Communications:** RS-232 adapter or RS-422/485 adapters with an RS-232 to RS-485 or USB to RS-485 converter may be used for communicating with the meters.
- Number of Meters:** Up to 100 meters simultaneously with addressing capability; minimum scan time for 100 meters: 60 sec
- Meter Address:** 00 to 99
- Baud Rate:** 300 bps to 19,200 bps; selection must match the baud rate selected in the meters.
- Screen Update Rate:** Dependent on system and meter settings. Rates of up to 10 meters/second are attainable at 19,200 bps.
- Configuration:** Configure meter settings one meter at a time.
- Configuration Report:** Save configuration to PDC file format or export to HTML for printing, cloning, or restoring meter .
- Logging Interval:** 2 seconds to 60 hours or manual
- Manual Logging:** Data saved to file when Log button is pressed.
- Data Logging Report:** Log data to HTML file format. All enabled meters are logged to a single file.
- Alarm Notification:** Pop-up message indicates new alarm condition. Alarm alert notification may be disabled.
- Event Log:** Important events are logged with date and time stamp.
- Relay/Alarm Status:** Indicate relay/alarm status with customized color and message label. Relay status indication may be disabled.
- Units & Tag Number:** Show engineering units and tag number information; these settings are not saved to the meter.
- Relay Acknowledge:** Relays may be acknowledged by clicking on corresponding Relay Status button. Meters must be set up for manual reset and Relay Mode must be enabled in MeterView.

Remote Meter Programming

MeterView® software allows all PD765 Trident setup parameters to be programmed from a PC and to save the configuration settings to a file for reporting or programming other meters.

Data Acquisition

MeterView® software provides a convenient way to collect the data generated by the Trident meters. The user can select the logging time interval and the engineering units that will be displayed on the computer screen. Data is written to a file that could then be imported into a spreadsheet or other application.

Data Logging up to 100 Trident Meters

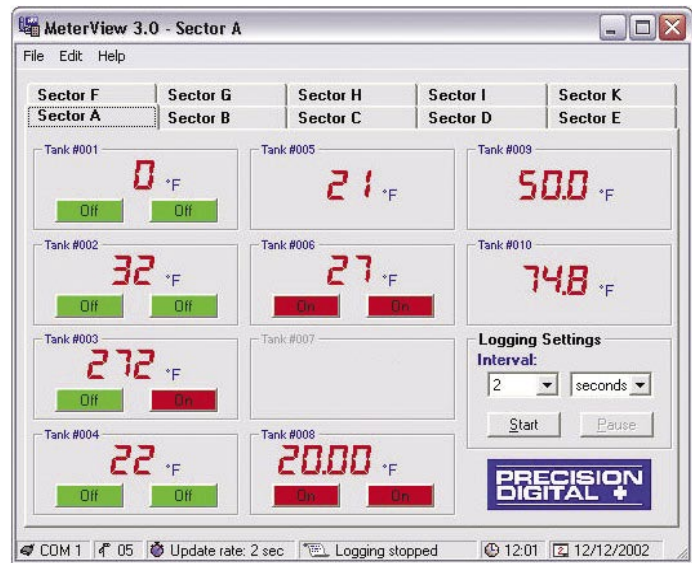

- Save data to a file
- Monitor up to 10 meters per tab
- 10 tabs = 100 meter total capacity
- Acknowledge relays

Sample File Generated by MeterView®

PD765 Log File						
Name: C:\MV3\logfile.htm			Created: 1/6/2006 5:34:12 PM			
Serial Port:	Connection speed:	Logging rate:				
COM 1	2400 Baud	1 update every 10 seconds				
Date & Time	Tag Number	Address	Display	Units	Relay 1	Relay 2
1/6/2006 5:34:12 PM	Tank 1 Level	06	17.70	Feet	P1 On	P2 Off
1/6/2006 5:34:12 PM	Tank 2 Level	07	18.18	Feet	P3 Off	P4 Off
1/6/2006 5:34:12 PM	Tank 3 Level	08	20.54	Feet	P5 On	P6 Off
1/6/2006 5:34:12 PM	Tank 1 Temp	09	74	°F	Off	Off
1/6/2006 5:34:12 PM	Tank 2 Temp	10	72	°F	Off	Off
1/6/2006 5:34:12 PM	Tank 3 Temp	11	72	°F	Off	Off
1/6/2006 5:34:22 PM	Tank 1 Level	06	17.58	Feet	P1 On	P2 Off
1/6/2006 5:34:22 PM	Tank 2 Level	07	18.04	Feet	P3 Off	P4 Off
1/6/2006 5:34:22 PM	Tank 3 Level	08	19.79	Feet	P5 Off	P6 Off
1/6/2006 5:34:22 PM	Tank 1 Temp	09	74	°F	Off	Off
1/6/2006 5:34:22 PM	Tank 2 Temp	10	72	°F	Off	Off

Great for tank level monitoring!

PROCESS & TEMPERATURE INPUTS

The Trident is factory calibrated to accept 4-20 mA, ± 10 VDC, type J, K, T, or E thermocouples and 100 Ω platinum RTDs. Process inputs can be scaled with or without applying an input for virtually any engineering units. Temperature inputs can be programmed to display in degrees Fahrenheit or Celsius and the type K thermocouple can display up to 2300 °F.

Current & Voltage Inputs

Setting up the meter to accept a current or voltage input could not be easier. All setup is performed with the front panel buttons and there are no switches or jumpers to deal with.

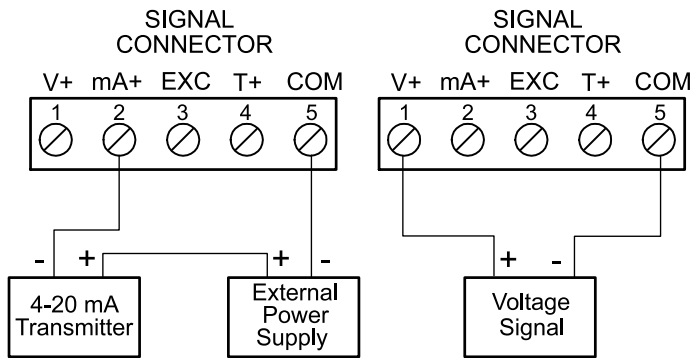

Transmitter Powered by External Supply

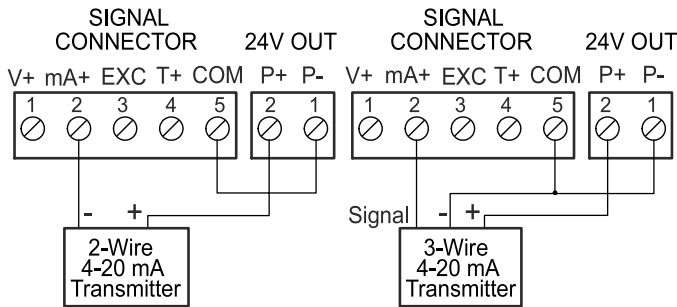

Transmitters Powered by Internal Supply (Optional)

Current Overload Protection

To protect the instrument from unexpected current overload the current input circuit contains a resettable fuse. The fuse limits the current to a safe level when it detects a fault condition, and automatically resets itself when the fault condition is removed.

Thermocouple & RTD Inputs

Setting up the Trident to accept a thermocouple or RTD input is simply a matter of setting a switch at the rear of the case and selecting the input type from the menu.

The meter accepts J, K, T, or E type thermocouples as well as two, three, or four-wire 100 Ω platinum RTDs.

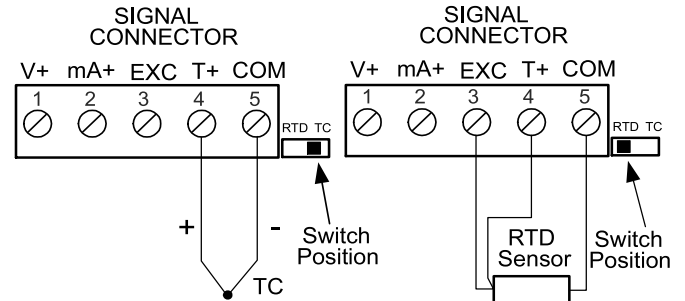

Thermocouple and RTD Inputs

Isolated 4-20 mA Analog Output

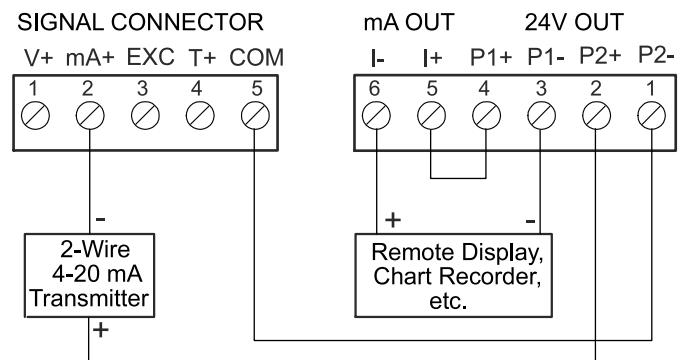

4-20 mA Output & Input Signal Powered by Meter

Connectors Location

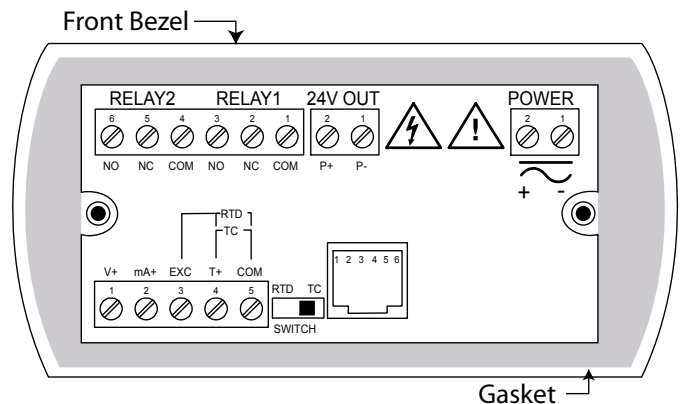

**Rear View
Meter with Relays Option**

FIELD ENCLOSURES

The Trident is available with a wide variety of NEMA 4, NEMA 4X, and explosion-proof enclosures.

NEMA 4 & NEMA 4X Enclosures

The NEMA 4 and NEMA 4X enclosures are available in stainless steel, steel, and plastic. They come with pre-punched 1/8 DIN cutouts for up to ten meters. The meters are mounted in the enclosure door so they can be programmed without opening the enclosure. Options include 2" pipe mounting kits and engraved plastic labels.

See page 146 of the 2005-2006 catalog for complete details and specifications of the NEMA 4 & NEMA 4X Enclosures.

Low-Cost Plastic NEMA 4X Enclosure

The PDA2801 is a low-cost, compact, plastic NEMA 4X enclosure that will house one meter.



Plastic, Steel & Stainless Steel



These NEMA 4 & 4X enclosures house from one to ten meters and feature a hinged door.

Enclosures and meters are ordered and packaged separately.

Engraved Plastic Labels

These custom engraved plastic labels are the perfect solution for identifying both the enclosure and labeling each individual meter

Whether the meters are mounted in one of our enclosures or installed into your existing control panel these custom engraved plastic labels are the answer you're looking for!

Explosion-proof Enclosures

These explosion-proof enclosures house one or two Tridents and are UL & C-UL Classified as NEMA 4, 7 & 9 for location in Class I, Groups C & D; Class II, Groups E, F, G; and Class III. Enclosures and meters are ordered and packaged separately.

ORDERING INFORMATION

Trident Model PD765		
85-265 VAC** Model	12-36 VDC** Model	Options Installed
PD765-6R0-00*	PD765-7R0-00	None
PD765-6R0-10*		24 VDC Transmitter Supply
PD765-6R2-00*	PD765-7R2-00	2 Relays
PD765-6R2-10*		2 Relays & 24 VDC Transmitter Supply
PD765-6R3-00	PD765-7R3-00	4-20 mA Output
PD765-6R3-10		4-20 mA Output & 24 VDC Supply
PD765-6R3-20		4-20 mA Output & Dual 24 VDC Supplies

To order meters with Modbus option enabled, replace the last digit with a "1". Modbus option ordered separately by requesting P/N: PDN-MODBUS.
 *Quick Shipment Program product, shipped within 2 working days.
 **All models may be powered from AC or DC, see Specifications for details.

Accessories	
Model	Description
PDA7420	Trident Meter Copy Cable, 7' (2.1 m)
PDA7232	Trident RS-232 Serial Adapter, PDA7420 Included
PDA7422	Trident RS-422/485 Serial Adapter, PDA7420 Included
PDA7485-I	RS-232 to RS-422/485 Isolated Converter
PDA7485-N	RS-232 to RS-422/485 Non-Isolated Converter
PDA7488	Trident RS-232 & RS-485 Isolated Multi-Input Adapter Board
PDA8485-I	USB to RS-422/485 Isolated Converter
PDA8485-N	USB to RS-422/485 Non-Isolated Converter
PDA7503-1	MeterView® Software for 1 Meter
PDA7503-2	MeterView® Software for 1-10 Meters
PDA7503-3	MeterView® Software for 1-100 Meters
PDN-MODBUS	Modbus Option Enable
PDX6901	Suppressor (snubber): 0.01 µF/470 Ω, 250 VAC

Setup, Calibration & Labels	
Model	Description
PDN-CAL	2-Point Input Calibration
PDN-CAL3	4-20 mA Output Calibration
PDN-CSETUP	Custom Setup
PDN-CERTCAL	Certificate of Calibration
PDN-CERTCAL2	Certificate of Calibration with Data
PDLXXXX	Engraved Plastic Labels

Ordering example: System consisting of 10 Tridents & MeterView®		
Qty	Model	Description
10	PD765-6R2-10	Trident with 2 Relays & 24 VDC Transmitter Supply
10	PDA7422	Trident RS-422/485 Serial Adapter
1	PDA8485-I	USB to RS-422/485 Isolated Converter
1	PDA7503-2	MeterView® Software for 1-10 Meters

SPECIFICATIONS

Except where noted all specifications apply to operation at +25°C.

General

Display: 0.56" (14.2 mm) red LED, 4 digits (-1999 to 9999)
Display Intensity: Eight user selectable intensity levels
Front Panel: NEMA 4X, IP65; panel gasket provided
Programming Methods: Four front panel buttons, cloning with Copy feature, PC with MeterView or LabVIEW software, and Modbus registers. Certified LabVIEW driver available.
Noise Filter: Programmable 2 to 199 (0 will disable filter)
Display Update Rate: Process/RTD: 3.7-5/sec; TC: 1.8-2.5/sec
Overrange: Display flashes 9999
Underrange: Display flashes -1999
Recalibration: All inputs are calibrated at the factory; recalibration is recommended at least every 12 months.
Max/Min Display: Stored until reset by user or meter is turned off.
Password: Restricts modification of programmed settings.
Non-Volatile Memory: Settings stored for a minimum of 10 years.
Power Options: 85-265 VAC, 50/60 Hz; 90-265 VDC, 20 W max or 12-36 VDC; 12-24 VAC, 6 W max.
Required Fuse: UL Recognized, 5 A max, slow-blow; up to 6 meters may share one fuse.
Normal Mode Rejection: 64 dB at 50/60 Hz
Isolation: 4 kV input/output-to-power line; 500 V input-to-output or output-to-24 VDC supplies
Operating Temperature: 0 to 65°C
Storage Temperature: -40 to 85°C
Relative Humidity: 0 to 90% non-condensing
Connections: Power & Signal: removable screw terminal blocks accept 12 to 22 AWG. Serial: RJ11 header, standard on all meters.
Enclosure: 1/8 DIN, high impact plastic, 94V-0, color; gray
Weight: 9.5 oz (269 g) (including options)
UL File Number: E160849; 508 Industrial Control Equipment
Warranty: 3 years parts & labor
Extended Warranty: 1 or 2 years, refer to Price List for details.

Process Inputs

Inputs: Field selectable: 0-20 mA, 4-20 mA, 1-5 V, ±10 V
Accuracy: ±0.05% FS ±1 count; square root: ±0.1% FS ±2 counts
Function: Linear or square root
Low-Flow Cutoff: 0 to 9999 (0 disables cutoff function)
Decimal Point: Up to 3 decimals: d.ddd, dd.dd, ddd.d, or dddd
Calibration: Scale without signal or calibrate with signal source
Calibration Range: User programmable over entire range of meter
Input Impedance: Voltage range: greater than 1 MΩ, Current range: 50-100 Ω, varies with resettable fuse impedance
Input Overload: Protected by automatically resettable fuse
Temperature Drift: ±50 PPM/°C
Transmitter Supply: Isolated, one or two transmitter supplies
 P1: 24 VDC ±10% @ 200 mA max (-1 option)
 P1 & P2: 24 VDC ±10% @ 200 mA & 40 mA max (-2 option)

Temperature Inputs

Inputs: Factory calibrated, field selectable: type J, K, T, or E thermocouples and 100 Ω platinum RTD (0.00385 or 0.00392 curve)
Resolution: 1°; type T: 1° or 0.1°
Cold Junction Reference: Automatic
Temperature Drift: ±2°C maximum
Offset Adjustment: Programmable to ±19.9°. This parameter allows the user to apply an offset value to the temperature being displayed.
Input Impedance: Greater than 100 kΩ
Sensor Break: All relays and alarm status LEDs go to alarm state.

Type	Range	Accuracy	Range	Accuracy
J	-58° to 1382°F	±2°F	-50° to 750°C	±1°C
K	-58° to 2300°F	±2°F	-50° to 1260°C	±1°C
T	-292° to 700°F	±2°F	-180° to 371°C	±1°C
E	-58° to 1700°F	±2°F	-50° to 927°C	±1°C
RTD	-328° to 1382°F	±1°F	-200° to 750°C	±1°C

Relays

Rating: 2 Form C (SPDT); rated 3 A @ 30 VDC or 3 A @ 250 VAC resistive load; 1/14 HP @ 125/250 VAC inductive loads
Deadband: 0-100% FS, user selectable
High or Low Alarm: User may program any alarm for high or low
Relay Operation:
 1. Automatic (non-latching) 2. Latching 3. Pump alternation control
Relay Reset: User selectable via front panel buttons or PC
 1. Automatic reset only (non-latching)
 2. Automatic plus manual reset at any time (non-latching)
 3. Manual reset only, at any time (latching)
 4. Manual reset only after alarm condition has cleared (latching)
Automatic Reset: Relays reset when input passes the reset point
Manual Reset: Front panel button, MeterView, Modbus registers
Time Delay: 0 to 199 seconds, on and off delays; programmable
Fail-Safe Operation: Programmable, independent for each relay. Relay coils are energized in non-alarm condition. In case of power failure, relays will go to alarm state.
Auto Initialization: When power is applied to the meter, relays will reflect the state of the input to the meter.

Isolated 4-20 mA Transmitter Output

Scaling Range: 1.00 to 23.00 mA; reverse scaling allowed.
Calibration: Factory calibrated 4.00 to 20.00 mA
Accuracy: ±0.1% FS ±0.004 mA
Temperature Drift: 50 PPM/°C
 Note: Analog output drift is separate from input drift
Isolation: 500 V input-to-output or output-to-24 VDC supplies; 4 kV output-to-power line
External Power: 35 VDC maximum
Output Loop Resistance:

Power Supply	Minimum Loop Resistance	Maximum Loop Resistance
24 VDC	10 Ω	700 Ω
35 VDC (external)	100 Ω	1200 Ω

Serial Communications

Compatibility: EIA-232, EIA-422, and EIA-485 with PDA7232 and PDA7422 Trident adapters.
Protocol: PDC and Modbus RTU
Meter Address: PDC protocol: 0 to 99, Modbus protocol: 1 to 247
Baud Rate: 300 to 19,200 bps
Transmit Time Delay: Programmable 0 to 199 ms or transmitter always on for RS-422 communications.
Data: 8 bit (1 start bit, 1 stop bit)
Parity: None, even, or odd (Modbus only; PDC protocol does not use parity)
Byte-to-Byte Timeout: 0.01 to 2.54 seconds (Modbus only)
Turn Around Delay: Less than 2 ms (fixed)
 Refer to PDC and Modbus Serial Communications Protocol manuals for details.



Your Local Distributor is

LDS765_G 01/06