



Series
V4

FLOTECT® Vane Operated Flow Switch

Field Adjustable — Dependable Protection Against Flow Variation or Stopping in Pipelines for Fluids, Gases and Flowing Solids



Flow

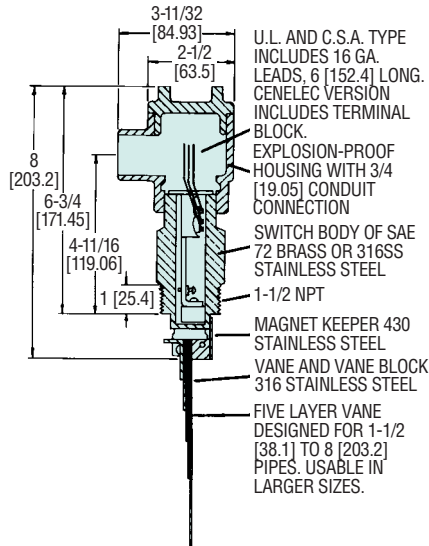

SPECIFICATIONS

Service: Gases or liquids compatible with wetted materials.

Wetted Materials:

Vane: 316 SS.

Body: Brass or 316 SS standard.

Magnet Keeper: 430 SS standard, 316 SS optional.

Options: Other materials also available, consult factory (e.g. PVC, Hastelloy, Nickel, Monel, Titanium).

Temperature Limit: -4 to 275°F (-20 to 135°C) standard, MT high temperature option 400°F (205°C) [MT option not UL, CSA, ATEX, or SAA].

Pressure Limit: Brass body 1000 psig (69 bar), 316 SS body 2000 psig (138 bar), optional 5000 psig (345 bar) available with 316 SS body and SPDT switch only.

Enclosure Rating: Weatherproof and Explosion-proof. Listed with UL and CSA for Class I, Groups C and D; Class II, Groups E, F, and G.

ATEX **CE** 0344 **Ex** II 2 G EEx d IIB T6 -20°C ≤ Tamb ≤ 75°C

EC-Type Certificate No.: KEMA 03ATEX 2383

SAA: Exd II C T6 (T amb=60°C). Zone I. Also FM approved.

Switch Type: SPDT snap switch standard, DPDT snap switch optional.

Electrical Rating: UL, FM, ATEX and SAA models 10A @ 125/250 VAC (V~). CSA models: 5A @ 125/250 VAC (V~); 5A res., 3A ind. @ 30 VDC (V--). MV option: 1A @ 125 VAC (V~); 1A res., .5A ind. @ 30 VDC (V--). MT option: 5A @ 125/250 VAC (V~). [MT and MV option not UL, CSA, FM, ATEX or SAA].

Electrical Connections: UL and CSA models: 16 AWG, 6" (152 mm) long. ATEX and SAA unit: Terminal block.

Conduit Connection: 3/4" female NPT.

Process Connection: 1-1/2" male NPT.

Mounting Orientation: Within 5° of vertical for proper operation. Units for horizontal installation (vertical pipe with up flow) available.

Set Point Adjustment: For universal vane: five vane combinations.

Weight: 4 lb 8 oz (1.9 kg).

Agency Approvals: UL, CSA, CE, FM, SAA, and ATEX.

Rugged and reliable the Flotect® V4 flow switch operates automatically to protect equipment and pipeline systems against damage from reduction or loss of flow. The V4 is time tested being installed in thousands of pipelines and processing plants around the world. A unique magnetically actuated switching design gives superior performance. There are no bellows, springs, or seals to fail. Instead, a free-swinging vane attracts a magnet within the solid metal switch body, actuating a snap switch by means of a simple lever arm.

FEATURES

- Leak proof body machined from bar stock
- Choice of custom vane calibrated for your application, Model V4, or field adjustable multilayer vane, Model V4-2-U (see set point chart)
- Weatherproof, designed to meet NEMA 4
- Explosion-proof (listing included in specifications)
- Installs directly and easily into pipeline with a thredolet, tee, or flange (see application drawings)
- Can be used in pipes 1-1/2" and up
- Electrical assembly can be easily replaced without removing the unit from installation so that the process does not have to be shut down
- High pressure rating of 1000 psig (69 bar) with the brass body and 2000 psig (138 bar) with the 316 SS body

APPLICATIONS

- Protects pumps, motors and other equipment against low or no flow
- Controls sequential operation of pumps
- Automatically starts auxiliary pumps and engines
- Stops liquid cooled engines, machines and processing when coolant flow is interrupted
- Shuts down burner when air flow through heating coil fails
- Controls dampers according to flow

STOCKED MODELS in bold

Model	Description
V4-2-U	Brass body, universal vane
V4-SS-2-U	316SS* body, universal vane
V4	Brass body, custom vane
V4-SS	316SS* body, custom vane

*316SS body with 430SS magnet keeper. For 316SS magnet keeper, specify: add -316

Options (add as a suffix to the model number):

-D, DPDT contacts

-MV, Gold Plated Contacts, options for dry circuits

(see electrical rating in specification, no listings or approvals)

-MT, High Temperature, option rated 400° F (204° C)

(see electrical rating in specifications, no listings or approvals)

-TRI (increasing flow), -TRD (decreasing flow), Time Delay Relay,

option with 2 SPDT contacts, adjustable from 0-1 to 0-31 minutes.

(no listings or approvals)

-316, 316 SS Magnet Keeper, option to replace standard 430 SS

-SAA, SAA listed construction

-V, Vertical Up Flow, option for upward flow in vertical pipe

-AT, ATEX listed construction

Consult factory for price and availability of fittings for V4 installation. Thredolets, bushings, and tees are available in a variety of sizes and materials.

For custom vane models, please supply factory with following information: pipe size, flow direction (horizontal, up), mounting, pressure, temperature, specific gravity, flow rates (maximum normal, actuation/deactuation*), etc.

*When both values are supplied, note which is critical.

V4 Universal Vane Flow Charts

Values shown in both charts are nominal. If normal flows exceed actuation rates by less than 10%, custom vanes are recommended. Figures are based on standard vertical installation in a 1-1/2" thredolet in a horizontal run of pipe.

FLOW

APPROXIMATE ACTUATION/DEACTUATION FLOW RATES FOR COLD WATER. UPPER FIGURES IN GPM. LOWER FIGURES IN LPM												
VANE LAYERS	1.5"PIPE	2"PIPE	3"PIPE	4"PIPE	6"PIPE	8"PIPE	10"PIPE	12"PIPE	14"PIPE	16"PIPE	18"PIPE	20"PIPE
1	7-3 26.67-11.67	15-8 56.7-30	45-22 167-83.3	95-40 367-150	210-120 800-450	375-175 1417-667	600-300 2267-1133	900-450 3400-1700	1200-600 4550-2267	1400-800 5300-3033	2000-1000 7567-3783	2400-1200 9083-4550
1&2		7-4 26.7-15	23-14 86.7-53.3	50-35 190-132	130-90 500-333	230-150 867-567	450-250 1700-950	650-350 2467-1317	900-500 3400-1900	1200-650 4550-2467	1450-800 5483-3033	1800-1000 6817-3783
1,2,&3			11-7 41.7-26.7	27-19 102-71.7	80-60 300-233	160-115 600-433	300-180 1133-683	450-275 1700-1033	600-350 2267-1317	750-450 2750-2083	1000-600 3783-2267	1200-700 4550-2650
1,2,3,&4				17-12 65-45	60-45 233-167	120-90 450-333	230-150 867-567	310-200 1167-750	430-280 1633-1067	550-360 2083-1367	700-450 2650-1700	850-550 3217-2083
1,2,3,4,&5					40-30 152-113	80-65 300-250	135-100 517-383	200-140 750-533	290-200 1100-750	360-250 1367-950	460-325 1733-1233	575-400 2183-1517

Actuation rates are based on cold water at a specific gravity of 1.0. For fluids of different specific gravity, actuation rates may be approximated by dividing the rate shown by the square root of the specific gravity.

APPROXIMATE ACTUATION/DEACTUATION FLOW RATES FOR AIR. UPPER FIGURES IN SCFM. LOWER FIGURES IN LPS												
VANE LAYERS	1.5"PIPE	2"PIPE	3"PIPE	4"PIPE	6"PIPE	8"PIPE	10"PIPE	12"PIPE	14"PIPE	16"PIPE	18"PIPE	20"PIPE
1	32-17 15-8	65-32 30-20	210-105 100-50	400-200 190-90	950-475 450-220	1550-850 730-400	2400-1300 1100-600	3450-1900 1600-900	4700-2600 2200-1200	6400-3500 3000-1700	8000-4400 3800-2100	10000-5500 4700-2600
1&2		23-13 10-6	120-70 60-30	195-140 90-70	550-375 260-180	1100-700 520-330	1850-1200 870-570	2700-1750 1300-800	3400-2200 1600-1000	4800-3100 2300-1500	6000-3900 2800-1800	7400-4800 3500-2300
1,2,&3			60-48 30-20	135-100 60-50	375-265 180-130	725-500 340-240	1200-850 570-400	1850-1300 870-610	2600-1800 1200-800	3350-2350 1600-1100	4300-3000 2000-1400	5300-3700 2500-1700
1,2,3,&4				65-50 30-20	260-200 120-90	500-400 240-190	875-700 410-330	1250-1000 590-470	1900-1500 900-710	2500-2000 1200-900	3100-2500 1500-1200	3900-3100 1800-1500
1,2,3,4,&5					130-100 60-50	310-250 150-120	650-525 310-250	1000-800 470-380	1600-1250 760-590	2200-1750 1040-830	2800-2250 1300-1100	3550-2850 1700-1300

Actuation rates are based on air at standard conditions. For gases at other pressures, temperatures, or specific gravities, consult factory for equivalent flow approximations.

APPLICATION DRAWINGS FOR FLOTECT® AUTOMATIC FLOW SWITCHES

